

RHM 40

Coriolis Mass Flow Meter for Demanding Applications

General Flow Control / Plant Balance / Terminal Transfer / Mixing
and Batching / High Temperature Fluids / Barge, Ship, Rail Car and
Truck Filing

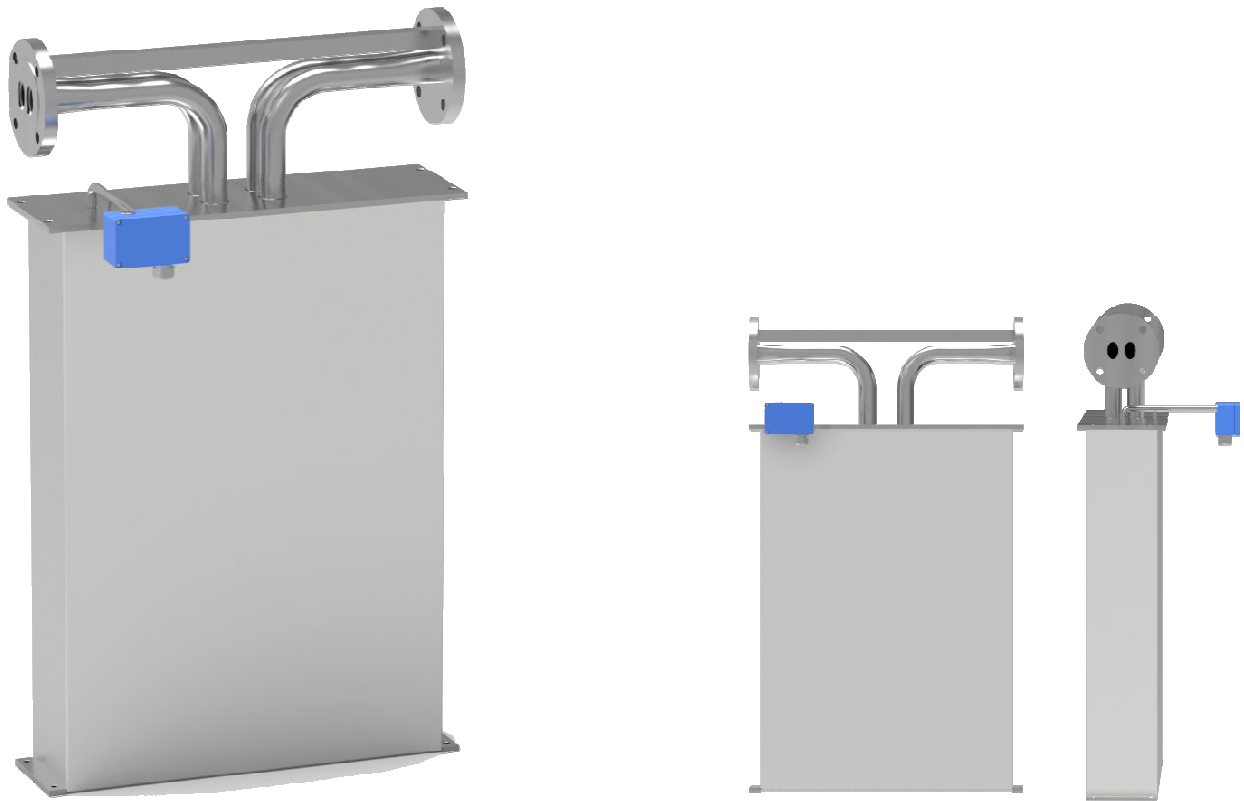



이점

- 유량 측정 범위 1,500 kg/min (3,306.93 lb/min)
- 압력 적용 범위 433 bar (6,280 psi)
- 온도 적용 범위 -196 to +350 °C (-320 to +662°F) - 더 넓은 범위 가능
- 질량 유량 정밀도 0.05 %
- 재현성 0.05 %
- 40 시리즈 트랜스미터와 함께 사용시 4 kHz 측정 업데이트 및 10ms 미만의 응답 속도
- 20 kg/min 미만까지 정확하게 측정
- 레오닉 **AnyPipeFit Commitment** 방법은 어떠한 프로세스 타입 및 사이즈에도 연결 가능하므로 설치 비용 절감
- Compact design 으로 최소 설치 공간 필요
- 방폭 인증 획득
- Stainless steel 외함 가능
- 일체형 및 분리형 트랜스미터 연결 가능

RHM40 일반 사양

Nominal Flow (Q_{nom})*	1200 kg/min (2645.6 lb/min)
Maximum Flow (Q_{max})*	1500 kg/min (3306.9 lb/min)
Typical Minimum Flow (Q_{min})*	20 kg/min (44.1 lb/min)
Serial Tube / Single Path	Flow rates Q_{max} , Q_{nom} and Q_{min} for "serial" sensors will be 50% of the above listed parallel/dual path version.
Operating Temperature	Fluid temperature range options cover applications from -196°C to +350°C (-320°F to +662°F). For integral transmitter versions please refer to transmitter datasheet
Ambient Temperature	-50 °C to +80 °C (-60 °F to +180 °F) (standard)
Pressure Ratings	Up to 433 bar / 6280 psi - dependent upon material
Electrical Connection Sensor w/o Integral Transmitter	M20 x 1.5 standard cable entry for JM, SM terminal box versions Optional entries available : ½" NPT or M25 x 1.5 (only for SM) or ¾" NPT (only for SM) Max. cable length to remote RHE transmitter 100 m / 328 ft
Sensor Enclosure Materials	Stainless steel 304 (standard), SS 316 (optional) Coated aluminum terminal box, SS 316 terminal box (optional)
Enclosure Type	Protection class IP66, NEMA 4X (standard), IP66/67, NEMA 4X/6 (optional)
Wetted Materials	1.4571 (SS 316Ti), 1.4410 (SuperDuplex), 2.4602 (Alloy C22) - standard Tantalum - Consult Factory Additional/customer specific materials available upon request
Process Connections	Nearly any – the Rheonik AnyPipeFit Commitment . Consult factory for types/sizes not listed in this data sheet on the Mechanical Construction pages
Pressure Rating Compliance	Europe – PED: Module A2, Module B3.1+C2 Canada – CRN: Canadian Registration Number
Certifications and Approvals	ATEX / IECEx Approvals for Zone 0, 1, 2 (details see page 12) North American Approvals Class I, Div. 1, 2, Gr. A,B,C,D, Zone 0, 1, 2 MID custody transfer approval (OIML R117) American Bureau of Shipping (ABS) Product Type Approval for use on marine vessels
Testing and Inspection	All sensors are hydro tested, calibrated and supplied with a traceable calibration certificate. Customized calibration and testing services are available
Project Documentation and QA, Services	Rheonik offers a full set of services for large and complex engineering projects. Typical services offered are, but not limited to: <ul style="list-style-type: none"> • Certificates of origin and conformity, mill certificates • Data books including WPAR, WQS, NDT, test & quality plans, functional testing, calibration procedures, customized packing, factory acceptance etc. • Painting to project specification • Start up and commissioning services on/offshore
Options	Enclosure heating for high temperature applications Cleaning for oxygen service , ... For more consult factory

* At Q_{nom} pressure drop across a parallel tube sensor will be approximately 1 bar (15 psi) for H2O. Sensors can be operated at higher flow rates up to Q_{max} but pressure drop will be higher. Typical Minimum Flow Q_{min} is the recommended lowest flow rate for an accurate measurement. Sensors will measure flow rates lower than Q_{min} but uncertainty will increase beyond 1 % of rate.

The flow rate specifications above relate to standard pressure, parallel tube, manifold sensor versions. Models with higher pressure ratings have increased wall thickness and will have higher pressure drops.

Calibration Options

Standard and Premium Calibration

A	0.20 % Uncertainty <i>Requires RHE 20 Series transmitter. All others 0.5 %</i>
B	0.15 % Uncertainty <i>Requires RHE 20 Series transmitter or higher</i>

Premium Plus and Ultimate Calibration

G	0.10 % Uncertainty <i>Requires RHE 20 Series transmitter or higher</i>
----------	--

Low Flow and Customized Calibration

1	0.10 % Low Flow Focused Calibration* <i>Requires RHE 40 Series transmitter</i>
X	Customized Calibration** <i>Consult factory</i>

* Low flow calibration focuses on the range from $Q_{nom}/2$ downwards to lower flow rates than on other calibrations. Often used for low pressure gas or very viscous liquids
 ** Customized calibration uses specific calibration points according to customer requirements

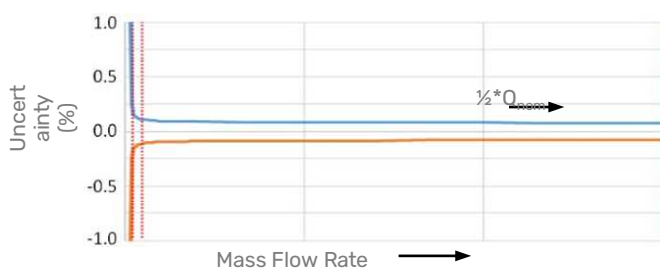

Density Calibration / Performance (Liquid)

N	No Density Calibration
S	Standard ± 0.001 kg/liter Uncertainty
D	Enhanced ± 0.0005 kg/liter Uncertainty

Uncertainties and flow measurement turn-down

The turn down capability from Q_{nom} of the flow sensor is driven mainly by its zero point stability. At the very low end of the measuring range the uncertainty (u) is dominated by the zero point stability. The zero stability of a standard sensor is: 0.15 kg/min (0.33 lbs/min). Zero point stability of a Gold Line sensor is 0.12 kg/min (0.27 lbs/min).

For flow $Q \geq ZP \text{ stability} / (\text{Base Calibration uncertainty}/100) \rightarrow u = \text{calibration uncertainty}$
 For flow $Q < ZP \text{ stability} / (\text{Base Calibration uncertainty}/100) \rightarrow u = (\text{zero stability}/Q) * 100$

Uncertainties from environmental and process conditions

- If sensors are not zeroed at operating conditions, minor additional uncertainties can arise from elevated temperatures and pressures: $\pm 0.000383 \%$ of maximum flow per $^{\circ}\text{C}$ and $\pm 0.000007 \%$ of maximum flow per bar.
- Process temperature effect on density: additional uncertainty of $\pm 0.000136 \text{ g/cm}^3$ per $^{\circ}\text{C}$ difference from calibration temperature with standard density calibration and of $\pm 0.000015 \text{ g/cm}^3$ per $^{\circ}\text{C}$ difference from calibration temperature with enhanced density calibration. This effect can be mitigated by a simple field density adjustment at operating conditions.
- Process pressure effect on mass flow: The effect of pressure on flow measurement is 0.001232 % of rate per bar. Compensation is possible by pressure sensor input (analog input or digital write) or manual value entry into the transmitter.
- Process pressure effect on density: The effect of pressure on density measurement is 0.0 g/cm³ per bar. Compensation is possible by pressure sensor input (analog input or digital write) or manual value entry into the transmitter.

Premium Plus, Low Flow and Enhanced Density Calibration come with Gold Line sensors and are not available in all materials, pressure and temperature ranges.

Reference conditions: 18–24 °C Water @ 1–3 bar; Gas (Natural gas) 35–100 bar.

Flow Measurement Repeatability

Standard Sensors $\pm 0.1 \%$ of rate
 Gold Line Sensors $\pm 0.05 \%$ of rate

Temperature Measurement

Better than $\pm 1^{\circ}\text{C}$

Pressure Drop

Every Coriolis flow sensor generates pressure drop across its inlet and outlet when in use. The amount of pressure drop generated is mainly a function of the flow velocity within its tubes and the flowing viscosity of the stream.

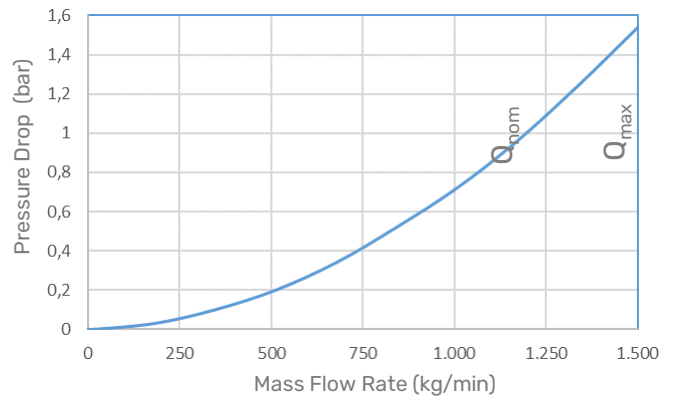

0 – 1500 kg/min water, sensor with P1 pressure rating. Higher viscosities create higher pressure drop

Measurement Tube Materials and Pressure Ratings

The maximum pressure (p_{max}) of a sensor is determined by its lowest rated part. The lowest rated part can be either the measurement tube (p_{max} see table to the right), the connection block/manifold (p_{max} indicated in the mechanical construction section) or the process connection (for p_{max} see published standards or manufacturer information).

Material	Pressure Code	50°C / 122°F	120°C / 248°F	210°C / 410°F	350°C / 662°F
SS 316Ti (standard)	P1	164 2379	147 2132	127 1842	107 1552
SuperDuplex*	P2	258 3742	242 3510	210 3046	n/a
SuperDuplex*	P3	433 6280	380 5511	343 4975	n/a

* Note minimum operating temperature for SuperDuplex stainless steel is -40 °C

Units: bar / psi

Other Materials

Other wetted materials may be possible for chemical compatibility, lower pressure drop, abrasion allowance, other application specific requirements. Rheonik can provide nearly any material for the wetted parts.
Contact factory with specification for assessment and availability.

Mechanical Construction

Sensors are manufactured with two internal measurement tubes arranged side by side. In parallel or dual path sensors (order code Pxx), these tubes are connected in parallel and the flowing fluid is split equally between them. In serial or single path sensors (order code Sxx), the internal tubes are connected end to end, creating a single path through which all fluid flows.

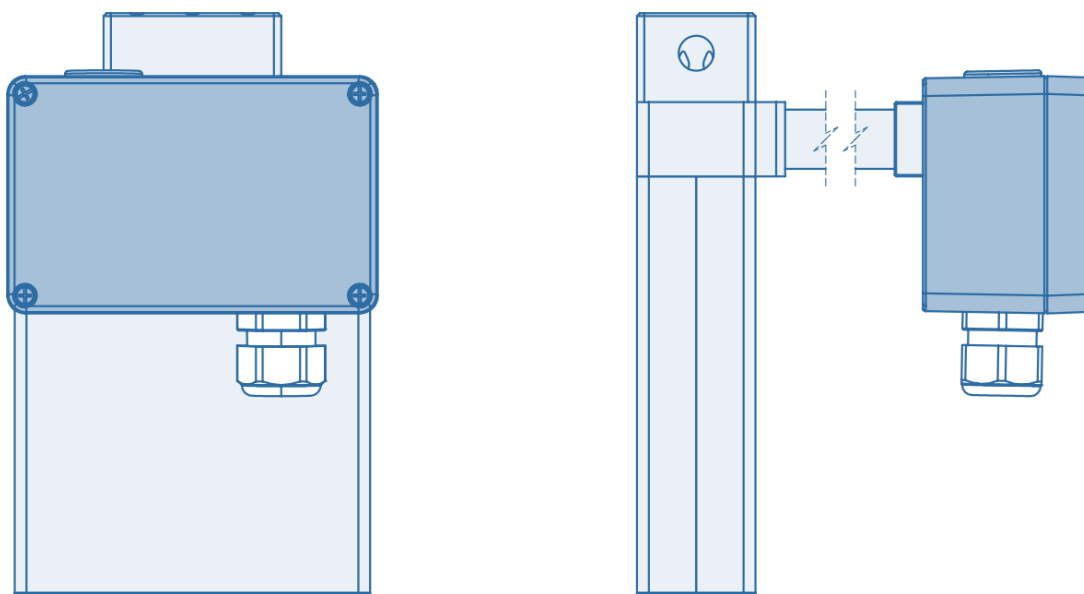

Note

All dimensions are for standard products. For customization of face to face length and/or process connection types other than the ones listed on this page, please consult factory. Note that larger diameter flange process connections are always possible.

Sealless design with flange connections

PFO: parallel / dual path

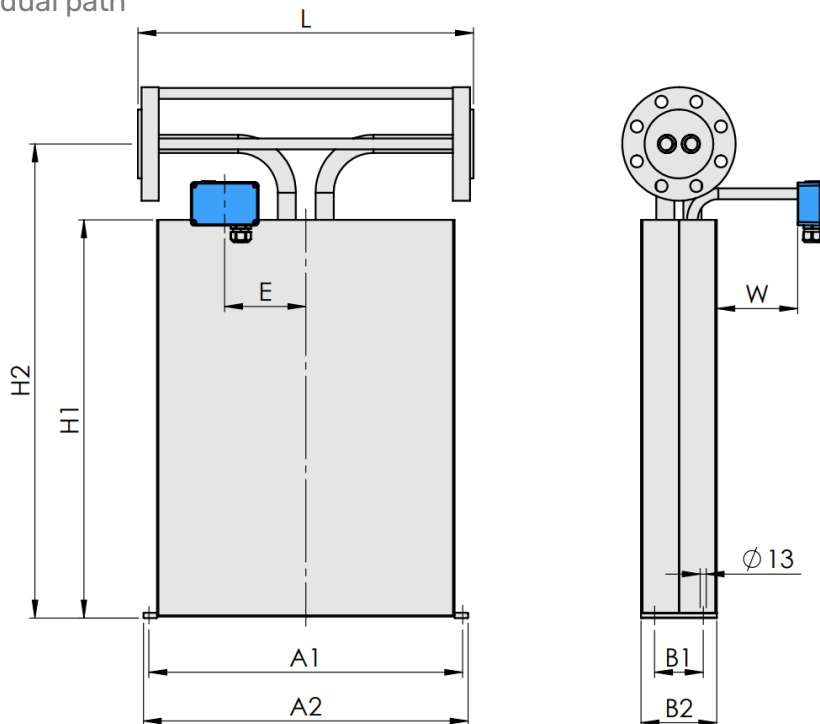

Process Connection PFO	Dim. L mm / in	Order Code
Flange ANSI 3" 150# RF/SF	725 / 28.54	A1
Flange ANSI 3" 300# RF/SF	725 / 28.54	A2
Flange ANSI 3" 600# RF/SF	725 / 28.54	A3
Flange ANSI 3" 900# RTJ	725 / 28.54	R6
Flange ANSI 3" 1500# RTJ	725 / 28.54	R1
Flange ANSI 3" 2500# RTJ	725 / 28.54	R2
Flange DIN DN80/PN40 Form B1	725 / 28.54	D1
Flange DIN DN80/PN100 Form B2	725 / 28.54	D2

PFO Dimensions	mm	in
A1	690	27.17
A2	720	28.35
B1	143	5.63
B2	180	7.09
H1	963	37.91
H2	1153	45.39
V	60	2.36
E	250	9.84
W	150	5.91

Weights and Shipping Dimensions

- Approx. weight with 3" 150# flanges: 140 kg / 309 lb
- Shipping in wooden crate as per ISPM 15, approx. 150 x 100 x 71 cm (60 x 40 x 28 in)
- Gross weight with 3" 150# flanges and RHE28 transmitter approx. 180 kg / 397 lb

Sealless design with flange connections

SFO: serial / single path

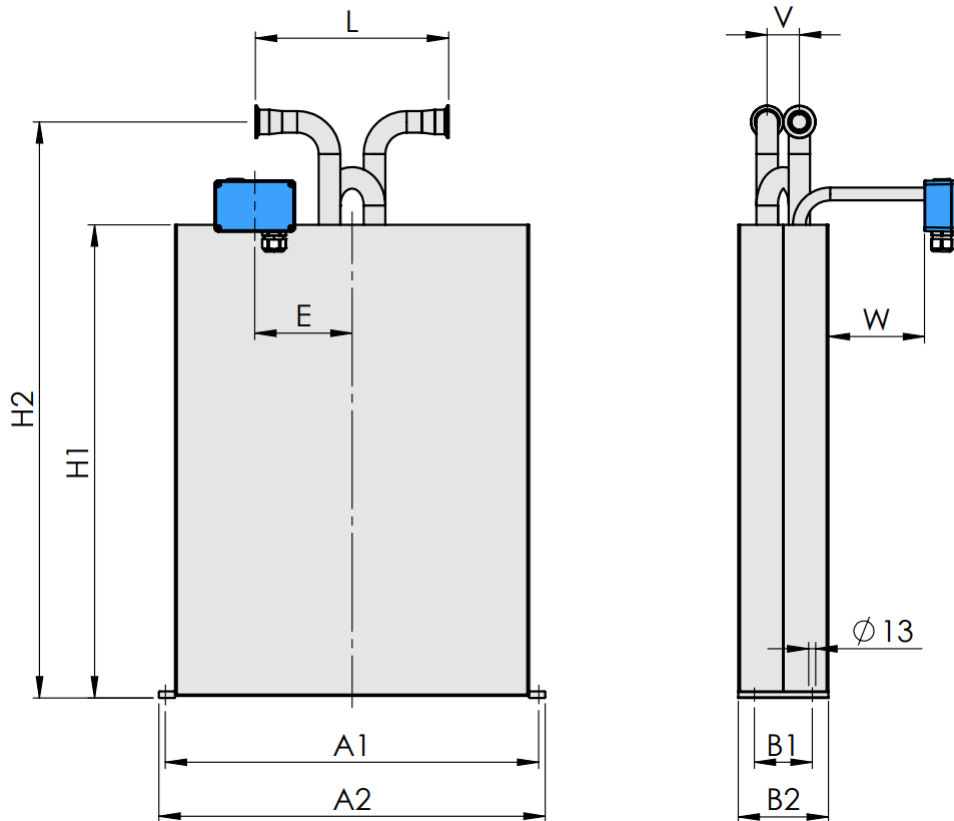

Process Connection SFO	Dim. L mm / in	Order Code
Sanitary 2" Triclam, DIN 32676	400 / 11.81	S1
Sanitary NW50, DIN 11851	400 / 11.81	S2

SFO Dimensions	mm	in
A1	690	27.17
A2	720	28.35
B1	143	5.63
B2	180	7.09
H1	963	37.91
H2	1153	45.39
V	60	2.36
E	250	9.84
W	150	5.91

Transmitter Range

Any Rheonik Mass Flow Transmitter model can be combined with any Rheonik Mass Flow Sensor to provide an overall mass flow measurement system to suit any requirement. Rheonik Coriolis Transmitters are available in versions specifically designed for process, industrial and OEM applications. Economical blind front versions of some transmitters are available where displays and keypads are not required. The wide range of sensors and transmitters provide tremendous options for system designers and end users alike.

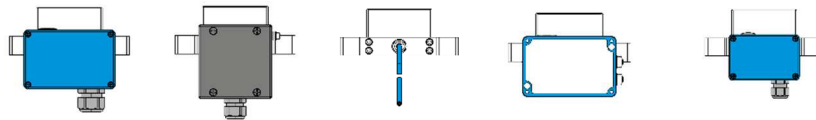

Product Code	JM	SM	TM	J5	PM
 RHE 21	✓	✓	✓	-	✓
 RHE 26	✓	✓	✓	-	✓
 RHE 27	✓	✓	✓	-	✓
 RHE 28	✓	✓	✓	-	✓
 RHE 42	✓	✓	✓	-	✓
 RHE 45	-	-	-	✓	-

Hazardous Area Certifications

Code	Zone / Division	Approval	Labeling
A0	Zone 0	ATEX	II 1G Ex ia IIC T6...T1 Ga
A1	Zone 1	ATEX	II 2G Ex ib IIC T6...T1 Gb
AB	Zone 0	ATEX	II 1G Ex ia IIB T6...T1 Ga
AB	Zone 1	ATEX	II 2G Ex ib IIB T6...T1 Gb
A2	Zone 2	ATEX	II 3G Ex ec IIC T6...T1 Gc
A0	Zone 0	IECEX	Ex ia IIC T6...T1 Ga
A1	Zone 1	IECEX	Ex ib IIC T6...T1 Gb
A2	Zone 2	IECEX	Ex ec IIC T6...T1 Gc
C0	Div 1, Zone 0	Zone USA/Kanada	Class I, Div 1, Groups A, B, C and D T6...T1; Class I, Zone 0, AEx ia IIC T6...T1 Ga
CB	Div 1, Zone 0	Zone USA/Kanada	Class I, Div 1, Groups C and D T6...T1; Class I, Zone 0, AEx ia IIB T6...T1 Ga
C2	Zone 2	Zone USA/Kanada	Class I, Zone 2, AEx nA IIC T6...T1 Gc



레오닉에 대해

레오닉의 목표는 최고의 Coriolis 질량유량계를 설계하고 제조하는 것입니다.

R&D 및 엔지니어링 팀은 효율적이고 정밀도가 뛰어난 새롭고 향상된 유량 솔루션을 제공하기 위해 전념하고 있으며, 생산 팀은 각각의 제품들에 대한 원자재 공급부터 제조, 운송까지 책임지고 서비스 및 지원 팀은 귀사에서 사용하는 모든 레오닉 제품을 분류, 통합, 시운전 및 유지 보수가 가능하도록 지원합니다.

레오닉 제품을 사용하신다면 귀사는 우리의 소중한 비즈니스 파트너입니다. 플랜트의 특별한 구성이 필요하다면 설치에 추가 비용이 발생하는 “표준” 제품 또는 광범위한 제품으로도 적합한 구성을 할 수 없는 경우에는 당사의 전용 “AnyPipeFit 실행” 으로 어떠한 유량 센서의 크기 또는 프로세스 커넥션 타입이라도 귀사가 원하는 제품으로 “맞춤제작” 할 수 있습니다.

귀사의 주 제품으로 어떤 제어 시스템을 사용하든 당사의 “AnyInterface 실행” 으로 설치 및 통신에 문제가 없습니다. 레오닉 RHE 트랜스미터는 다양한 아날로그 또는 디지털 신호와 함께 모든 네트워크/bus 인터페이스 (HART, ProfibusDP, ProfiNet, EtherCAT, PowerLink, EtherNet/IP, CAN 등)를 제공합니다. 레오닉 RHE 트랜스미터는 귀사의 시스템에 (어려운 문제 및 변환이 필요 없이) 연결하여 사용 가능합니다.



(주)레오닉코리아

#07547

서울시 강서구 양천로 583

우림블루나인 비즈니스센터

A동 1008호

www.rheonik.kr
info@rheonik.kr
02-3664-5015

