



RHM 10

Coriolis Mass Flow Meter for Batching/Filling and Accurate Measurement

General Flow Control / Additive Dosing / Mixing and Batching /
Chemical Injection / Package and Container Filling / Hydrogen
Dispensers for Trucks, Trains & Buses





이점

- 유량 측정 범위 90 kg/min(198.42 lb/min)
- 압력 적용 범위 1,379 bar (20,000 psi)
- 온도 적용 범위 -196 to +350°C (-320 to +662°F)
- 질량 유량 정밀도 0.05 %
- 재현성 0.05 %
- 40 시리즈 트랜스미터와 함께 사용시 4 kHz 측정 업데이트 및 10ms 미만의 응답 속도
- 250 g/min 미만까지 정확하게 측정
- 레오닉 **AnyPipeFit Commitment** 방법은 어떠한 프로세스 타입 및 사이즈에도 연결 가능하므로 설치 비용 절감
- Compact design 으로 최소 설치 공간 필요
- 방폭 인증 획득
- Stainless steel 외함 가능
- 일체형 및 분리형 트랜스미터 연결 가능

RHM10 일반사양

| | |
|--|--|
| Nominal Flow (Q_{nom})* | 60 kg/min (132 lb/min) |
| Maximum Flow (Q_{max})* | 90 kg/min (198 lb/min) |
| Typical Minimum Flow (Q_{min})* | 0.25 kg/min (0.55 lb/min) |
| Serial Tube / Single Path | Flow rates Q_{max} , Q_{nom} and Q_{min} for "serial" sensors will be 50 % of the above listed parallel/dual path version. |
| Operating Temperature | Fluid temperature range options cover from -196 °C to +350 °C (-320 °F to +662 °F) For integral transmitter versions please refer to transmitter datasheet |
| Ambient Temperature | -50 °C to +80 °C (-60 °F to +180 °F). High temperature version for oven installation up to +210 °C (+410 °F) available |
| Pressure Ratings | Up to 1379 bar / 20000 psi – dependent upon material |
| Electrical Connection Sensor w/o Integral Transmitter | M20 x 1.5 standard cable entry for JM, SM terminal box versions Optional entries available : ½" NPT or M25 x 1.5 (only for SM) or ¾" NPT (only for SM) M16 x 1.5 standard cable entry for PM terminal box version Max. cable length to remote RHE transmitter 100 m/330 ft |
| Sensor Enclosure Materials | Stainless steel 304 (standard), SS 316L (optional) Coated aluminum terminal box, SS 316L terminal box (optional) |
| Enclosure Type | Protection class IP66 (IP66 is mostly equivalent to NEMA 4X) Optionally IP66-IP67 (IP67 declared by manufacturer, IP67 is mostly equivalent to NEMA 6) |
| Wetted Materials | Flow tubes SS 316L, SuperDuplex, Sandvik HP160© or Alloy C22 Manifolds SS 316L, seals FKM, FFKM, FVMQ, EPDM Standard flanges SS 316Ti, other connections SS 316L Additional/customer specific materials available upon request |
| Process Connections | Nearly any - The Rheonik AnyPipeFit Commitment covers a wide range of process connections types and sizes. Consult factory for types/sizes not listed in this data sheet on the Mechanical Construction pages |
| Pressure Rating Compliance | PED 2014/68/EU Article 4, Section 3 (SEP) |
| Certifications and Approvals | ATEX / IECEx Approvals Zone 0, 1, 2 (see page 20) North American Approvals Cl. I, Div. 1, 2, Gr. A, B, C, D, Zone 0, 1, 2 OIML, MID custody transfer approval American Bureau of Shipping (ABS) DNV approval for marine applications |
| Testing and Inspection | All sensors are hydro tested, calibrated and supplied with a traceable calibration certificate. Customized calibration and testing services are available |
| Project Documentation and QA, Services | Rheonik offers a full set of services for large and complex engineering projects. Typical services offered are, but not limited to: <ul style="list-style-type: none"> • Certificates of origin and conformity, mill certificates • Data books including WPS-WPQR, WPQ, NDT, test & quality plans, functional testing, calibration procedures, customized packing, factory acceptance etc. • Painting to project specification • Start up and commissioning services on/offshore |
| Options | Customization services for machine integration. Consult factory |

* At Q_{nom} pressure drop across a parallel tube sensor will be approximately 2.2 bar (32 psi) for H₂O. Sensors can be operated at higher flow rates up to Q_{max} but pressure drop will be higher. Typical Minimum Flow Q_{min} is the recommended lowest flow rate for an accurate measurement. Sensors will measure flow rates lower than Q_{min} but uncertainty will increase beyond 1 % of rate.

The flow rate specifications above relate to standard pressure, parallel tube, manifold sensor versions. Models with higher pressure ratings have increased wall thickness and will have higher pressure drops.

Calibration Options

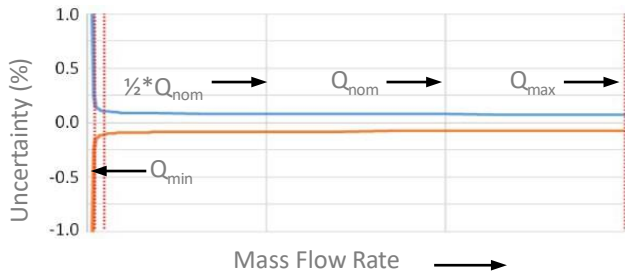

| Order Code | General Accuracy Calibration |
|------------|-------------------------------|
| A | Standard - 0.20 % Uncertainty |
| B | Premium - 0.15 % Uncertainty |

| Order Code | High Accuracy Calibration |
|------------|--|
| G | Premium Plus - 0.10 % Uncertainty |
| U | Ultimate - 0.05 % Uncertainty <i>Requires RHE 40 Series transmitter</i> |

| Order Code | Focused Calibration |
|------------|---|
| 1 | 0.10 % Low Flow Calibration* <i>Requires RHE 40 Series transmitter</i> |
| X | Customized Calibration** Consult factory |

* Low flow calibration focuses on the range from $\frac{1}{2} * Q_{nom}$ downwards to lower flow rates than on other calibrations. Often used for low pressure gas or very viscous liquids

** Customized calibration uses specific calibration points according to customer requirements

Reference conditions:

18-24°C Water @ 1-3 bar

| Order Code | Density Calibration / Performance (Liquid) |
|------------|---|
| N | No Density Calibration |
| S | Standard ± 0.001 kg/l Uncertainty |
| D | Enhanced ± 0.0005 kg/l Uncertainty Requires High Accuracy or Focused Calibration Option |

Uncertainties and flow measurement turn-down

The turn down capability from Q_{nom} of the flow sensor is driven mainly by its zero point stability. At the very low end of the measuring range the uncertainty (u) is dominated by zero point stability.

- Zero point stability of a standard sensor with General Accuracy Calibration is: 0.00246 kg/min (0.00542 lbs/min).
- Zero point stability of a Gold Line sensor with High Accuracy or Focused Calibration is 0.0012 kg/min (0.00265 lbs/min).
- For flow $Q \geq ZP$ stability / (Base Calibration uncertainty/100) $\rightarrow u =$ calibration uncertainty
- For flow $Q < ZP$ stability / (Base Calibration uncertainty/100) $\rightarrow u =$ (zero stability/Q) * 100

Uncertainties from environmental and process conditions

If sensors are not zeroed at operating conditions, minor additional uncertainties can arise from elevated temperatures and pressures:

- ± 0.000556 % of maximum flow per °C
- ± 0.000333 % of maximum flow per bar.

Process temperature effect on density:

- Additional uncertainty of ± 0.000122 g/cm³ per °C difference from calibration temperature with standard density calibration
- Additional uncertainty of ± 0.000036 g/cm³ per °C difference from calibration temperature with enhanced density calibration.
- This effect can be mitigated by a simple field density adjustment at operating conditions.

Process pressure effect on mass flow:

The effect of pressure on flow measurement is 0.0001 % of rate per bar. Compensation is possible by pressure sensor input (analog input or digital write) or manual value entry into the transmitter.

Process pressure effect on density:

- The effect of pressure on density measurement is 0.000075 g/cm³ per bar. Compensation is possible by pressure sensor input (analog input or digital write) or manual value entry into the transmitter.

Premium Plus, Ultimate, Low Flow and Enhanced Density Calibration are only available in SS316 material, P1 lower pressure and N1 temperature range.

Applying Premium Plus calibration to higher pressure, special materials and/or non-standard temperature models will show higher zero uncertainties (up to 3 times higher than standard sensor).

Flow Measurement Repeatability

Standard Sensors ± 0.1 % of rate Gold Line Sensors ± 0.05 % of rate

Temperature Measurement

Better than ± 1 °C

Pressure Drop

Every Coriolis flow sensor generates pressure drop across its inlet and outlet when in use. The amount of pressure drop generated is mainly a function of the flow velocity within its tubes and the flowing viscosity of the stream.

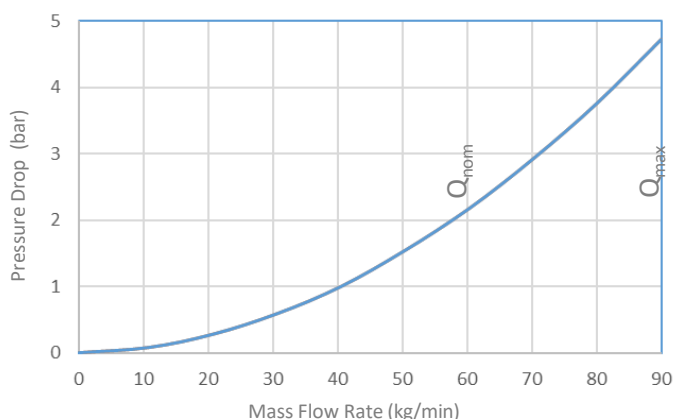

0 – 90 kg/min water, sensor with P1 pressure rating. Higher viscosities create higher pressure drop

Measurement Tube Materials and Pressure Ratings

The maximum pressure (p_{max}) of a sensor is determined by its lowest rated part. The lowest rated part can be either the measurement tube (p_{max} see table to the right), the connection block/manifold (p_{max} indicated in the Mechanical Construction section) or the process connection (for p_{max} see published standards or manufacturer information).

Note:

The material of the connection block/manifold is always SS 316L.

The material of the process connection of sealless sensor versions is usually the same as the measurement loops, however, could be different in special cases on PFT.

| Order Code | Material | 50°C / 122°F | 120°C / 248°F | 210°C / 410°F | 350°C / 662°F |
|------------|--------------------|---------------|---------------|---------------|---------------|
| P1 | SS 316L (standard) | 208 3017 | 185 2683 | 156 2263 | 133 1929 |
| P1 | Alloy C22 | 341 4945 | 303 4394 | 258 3741 | 214 3103 |
| P2 | SuperDuplex* | 481 6976 | 448 6498 | 402 5831 | N/A |
| P2 | Sandvik HP160® | 600 8702 | 540 7832 | 490 7107 | N/A |
| P3 | SuperDuplex* | 753 10921 | 701 10167 | 629 9123 | N/A |
| P3 | Sandvik HP160® | 1010 14649 | 970 14069 | 650 9472 | N/A |
| P4 | SuperDuplex* | 1379 20000 | 1289 18695 | 1156 16766 | N/A |

* Note minimum operating temperature for SuperDuplex stainless steel is -40 °C

Units: bar / psi

Other Materials

Other wetted materials may be possible for chemical compatibility, lower pressure drop, abrasion allowance, other application specific requirements. Rheonik can provide nearly any material for the wetted parts.

Contact factory with specification for assessment and availability.

Mechanical Construction

Sensors are manufactured with two internal measurement tubes arranged side by side. In parallel or dual measurement path sensors (order code Pxx), these tubes are connected in parallel, and the flowing fluid is split equally between them. In serial or single measurement path sensors (order code Sxx), the internal tubes are connected end to end, creating a single path through which all fluid flows. Manifold designs have a removable inlet/outlet block/manifold and utilize seals between the manifold and sensor body. In sealless designs, the measurement tubes are continuous between the process connections and do not have seals. Manifold designs typically offer shorter delivery lead times and may have a lower pressure drop than sealless designs for the same flow rate.

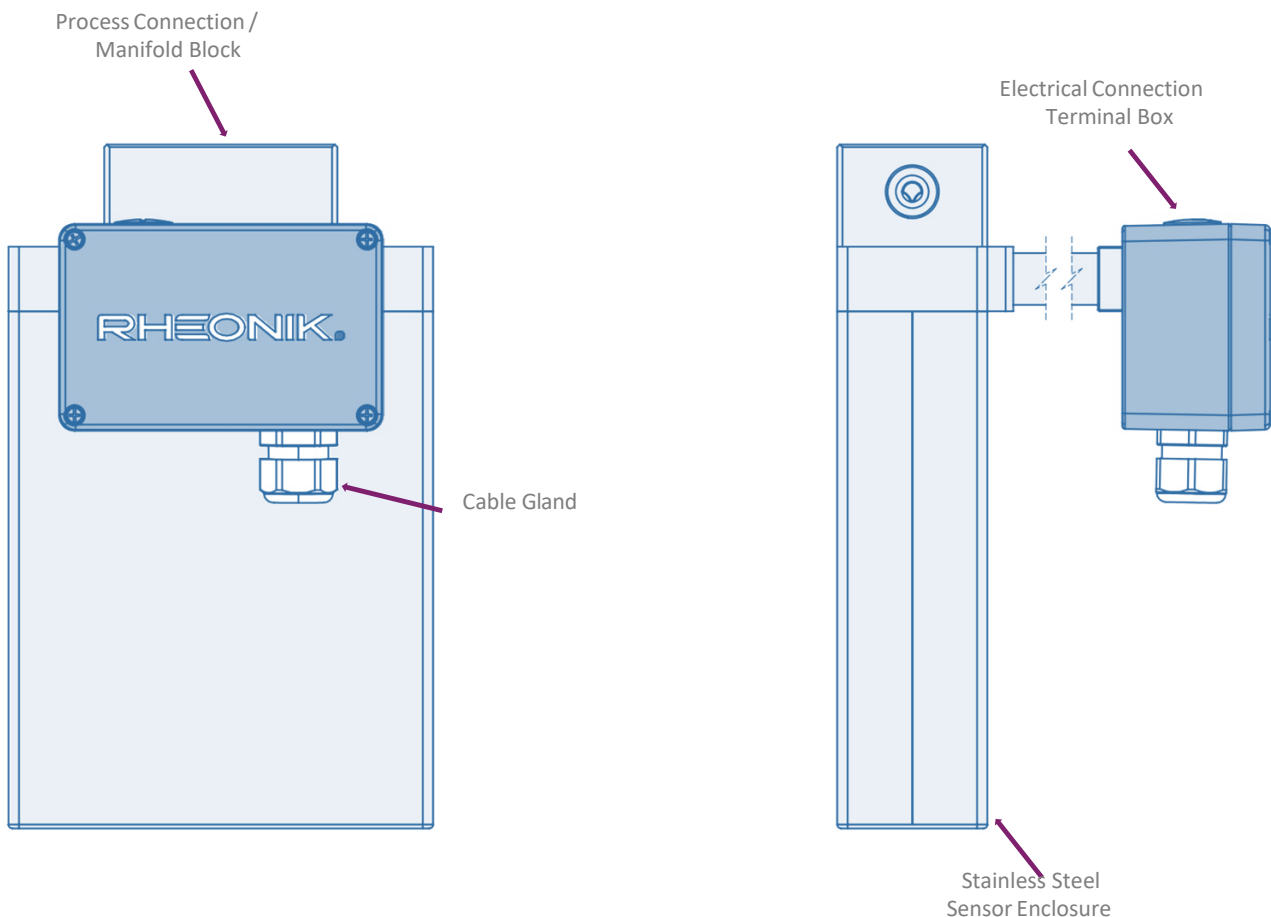

Note

All dimensions in the following pages are for standard design products. For customization of face-to-face length and/or process connection types other than the ones listed on the following page, please consult factory. Note that larger diameter flange process connections are always possible. The tolerance of the process connections is ± 2 mm.

Manifold design with threaded process connections

Parallel tube / dual measurement path Order

Codes: PM0/PH0

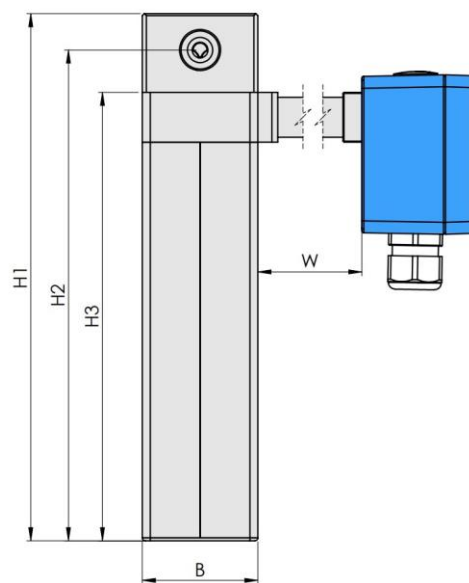
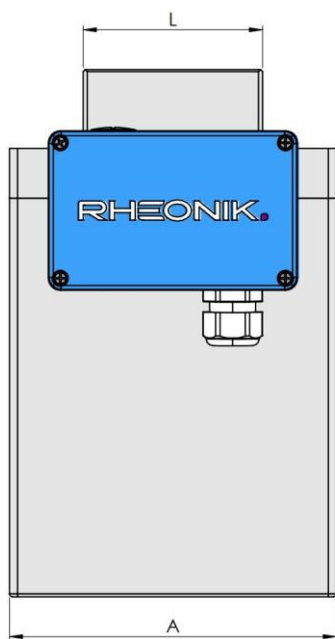

| PM0 / PH0 Process Connection | Dim. L mm / in | Order Code |
|--|-------------------|---------------|
| Female Thread G 1/2" - PM0 | 80 / 3.15 | G1 |
| Female Thread 1/2" NPT- PM0 | 80 / 3.15 | N1 |
| Autoclave 9/16" MP - 13/16" - 16 UNF Female Thread (only PH0) | 90 / 3.54 | P2 |

| PM0 / PH0 Dimensions | mm | in |
|-------------------------|-------------|-------|
| A | 189 | 7.44 |
| B | 58 | 2.28 |
| H1 (PM0, PH0) | 305 | 12.01 |
| H2 | 286 | 11.26 |
| H3 | 265 | 10.43 |
| W | see page 15 | |

Manifold Pressure Ratings @ 120 °C / 248 °F

PM0 – 700 bar / 10150 psi

PH0 – 1220 bar / 17695 psi (20000 psi @ 50 °C / 122 °F)

Weights and Shipping Dimensions

- Weight for sensor with threads:
~7 kg/15.4 lb
- Shipping carton size: ~50 x 50 x 50 cm (20 x 20 x 20 in)
- Gross weight with RHE28, packaging:
~13 kg/28.7 lb

Material of Manifold and Seals (Wetted Part) The connection block/manifold is made of SS316L. Depending upon sensor temperature range, sensors are supplied with the following seal types as standard. For alternative seal options (e.g., FFKM seals for N1) please see Options Codes on page 19. Other seals on request.

| Temperature Range | PM0 | PH0 |
|-------------------|-------|------|
| N1 | FKM | FKM |
| NA | FVMQ | FVMQ |
| E2 | FFKM* | n/a |

*FFKM seals minimum temperature is -20 °C/-4 °F; $p_{max} = 700$ bar

Manifold design with threaded process connections

Serial tube / single measurement path Order

Codes: SM0

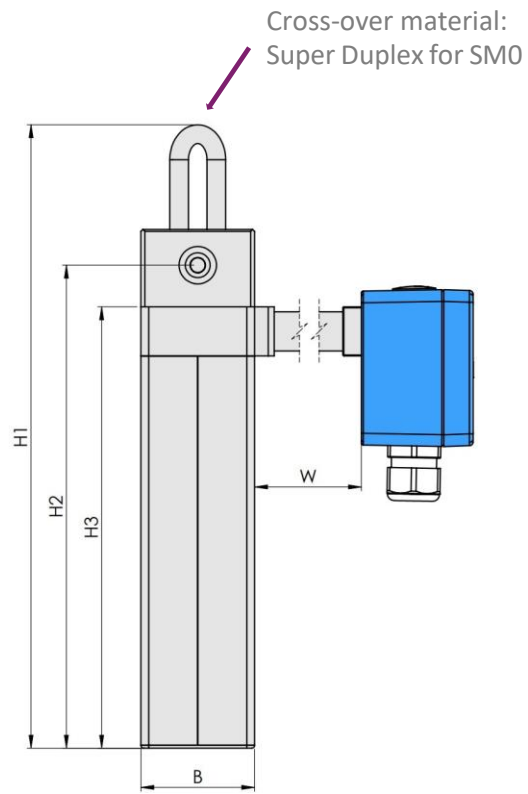
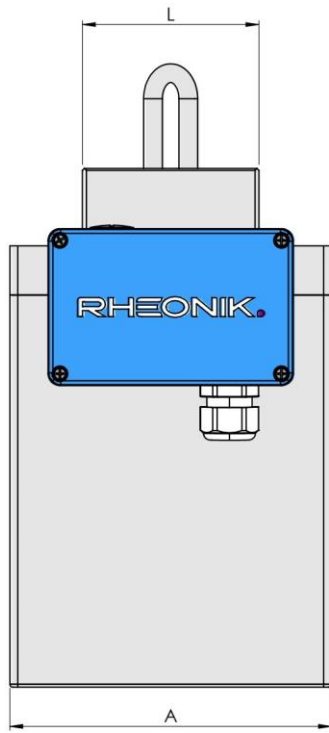

| SM0 Process Connection | Dim. L mm / in | Order Code |
|------------------------------|----------------|------------|
| Female Thread G 1/2" - SM0 | 90 / 3.54 | G1 |
| Female Thread 1/2" NPT - SM0 | 90 / 3.54 | N1 |

| SM0 Dimensions | mm | in |
|----------------|-------------|-------|
| A | 189 | 7.44 |
| B | 58 | 2.28 |
| H1 | 358 | 14.09 |
| H2 | 286 | 11.26 |
| H3 | 265 | 10.43 |
| W | see page 15 | |

Manifold Pressure Ratings @ 120 °C / 248 °F

SM0 – 700 bar / 10150 psi

Weights and Shipping Dimensions

- Weight for sensor with threads: ~7 kg/15.4 lb
- Shipping carton size: ~50 x 50 x 50 cm (20 x 20 x 20 in)
- Gross weight with RHE28, packaging: ~13 kg/28.7 lb

Material of Manifold and Seals (Wetted Part)

The connection block/manifold is made of SS316L. Depending upon sensor temperature range, sensors are supplied with the following seal types as standard. For alternative seal options (e.g., FFKM seals for N1) please see Options Codes on page 19. Other seals on request.

| Temperature Range | SMO |
|-------------------|-------|
| N1 | FKM |
| NA | FVMQ |
| E2 | FFKM* |

*FFKM seals minimum temperature is -20 °C/-4 °F; p_{max} = 700 bar

Manifold design with flanged process connections

Parallel tube / dual measurement path Order

Code: PM0

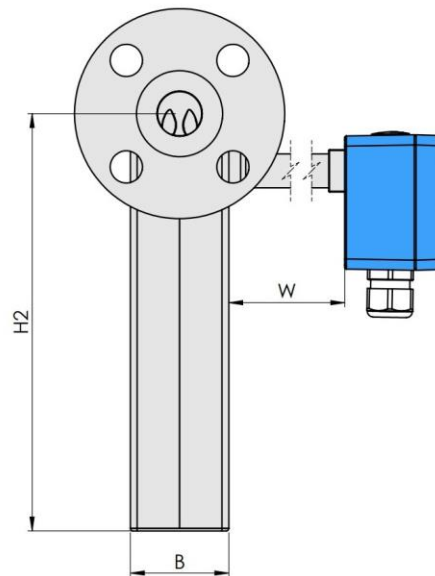
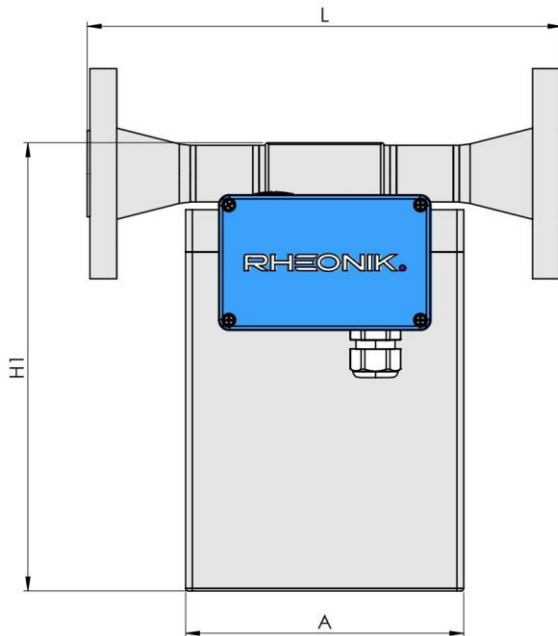

| PMO Process Connection | Dim. L mm / in | Order Code |
|--|----------------|------------|
| Standard | | |
| Flange ANSI 1" 150# RF/SF | 280 / 11.02 | A1 |
| Flange ANSI 1" 300# RF/SF | 280 / 11.02 | A2 |
| Flange ANSI 1" 600# RF/SF | 300 / 11.81 | A3 |
| Flange ANSI 1" 1500# RF/SF | 340 / 13.39 | A4 |
| Flange ANSI 1" 1500# RTJ | 340 / 13.39 | R1 |
| Flange DIN DN25/PN40 Form B1 | 280 / 11.02 | D1 |
| Flange DIN DN25/PN100 Form B2 | 300 / 11.81 | D2 |
| Flange JIS B 2220 RF 10k 25A (1") | 280 / 11.02 | J1 |
| Flange JIS B 2220 RF 20k 25A (1") | 280 / 11.02 | J2 |
| Non-Standard (longer lead times, extra price) | | |
| Flange ANSI ½" 150# RF/SF | 260 / 10.24 | AA |
| Flange ANSI ½" 300# RF/SF | 260 / 10.24 | AB |
| Flange ANSI ½" 600# RF/SF | 280 / 11.02 | AC |
| Flange ANSI ½" 1500# RTJ | 320 / 12.60 | RA |
| Flange DIN DN15/PN40 Form B1 | 280 / 11.02 | DA |
| Flange DIN DN15/PN100 Form B2 | 280 / 11.02 | DB |
| Flange JIS B 2220 RF 10k 15A (1/2") | 260 / 10.24 | JA |
| Flange JIS B 2220 RF 20k 15A (1/2") | 260 / 10.24 | JB |

| PMO Dimensions | mm | in |
|----------------|-------------|-------|
| A | 189 | 7.44 |
| B | 58 | 2.28 |
| H1 (PM0) | 305 | 12.01 |
| H2 | 286 | 11.26 |
| H3 | 265 | 10.43 |
| W | see page 15 | |

Material of Manifold and Seals (Wetted Part) The connection block/manifold is made of SS316L. Depending upon sensor temperature range, sensors are supplied with the following seal types as standard. For alternative seal options (e.g., FFKM seals for N1) please see Options Codes on page 19. Other seals on request.

| Temperature Range | PMO |
|-------------------|-------|
| N1 | FKM |
| NA | FVMQ |
| E2 | FFKM* |

Weights and Shipping Dimensions

- Weight for sensor with 1" 150# flanges: ~9 kg/19.8 lb
- Shipping carton size: ~50 x 50 x 50 cm (20 x 20 x 20 in)
- Gross weight with RHE28, packaging: ~15 kg/33.1 lb

*FFKM seals minimum temperature is -20 °C/-4 °F; $p_{max} = 700$ bar

Manifold design with flanged process connections

Parallel tube / dual measurement path Order

Code: SMO

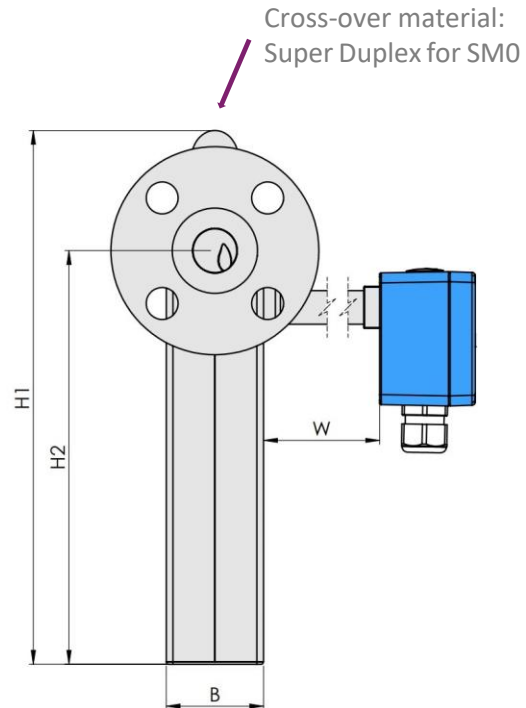
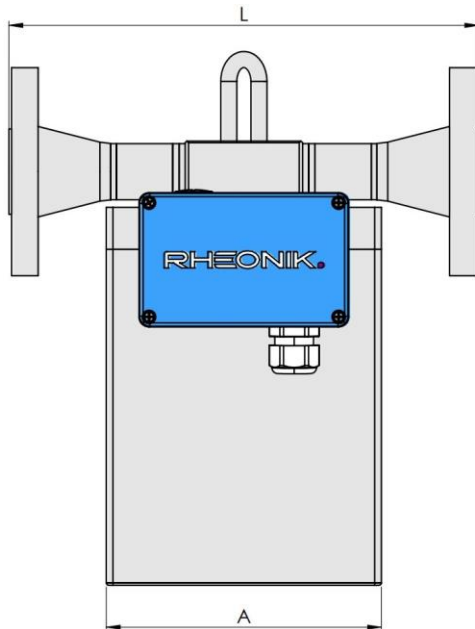

| SMO Process Connection | Dim. L mm / in | Order Code |
|--|----------------|------------|
| Standard | | |
| Flange ANSI 1" 150# RF/SF | 280 / 11.02 | A1 |
| Flange ANSI 1" 300# RF/SF | 280 / 11.02 | A2 |
| Flange ANSI 1" 600# RF/SF | 300 / 11.81 | A3 |
| Flange ANSI 1" 1500# RF/SF | 340 / 13.39 | A4 |
| Flange ANSI 1" 1500# RTJ | 340 / 13.39 | R1 |
| Flange DIN DN25/PN40 Form B1 | 280 / 11.02 | D1 |
| Flange DIN DN25/PN100 Form B2 | 300 / 11.81 | D2 |
| Flange JIS B 2220 RF 10k 25A (1") | 280 / 11.02 | J1 |
| Flange JIS B 2220 RF 20k 25A (1") | 280 / 11.02 | J2 |
| Non-Standard (longer lead times, extra price) | | |
| Flange ANSI 1/2" 150# RF/SF | 260 / 10.24 | AA |
| Flange ANSI 1/2" 300# RF/SF | 260 / 10.24 | AB |
| Flange ANSI 1/2" 600# RF/SF | 280 / 11.02 | AC |
| Flange ANSI 1/2" 1500# RTJ | 320 / 12.60 | RA |
| Flange DIN DN15/PN40 Form B1 | 280 / 11.02 | DA |
| Flange DIN DN15/PN100 Form B2 | 280 / 11.02 | DB |
| Flange JIS B 2220 RF 10k 15A (1/2") | 260 / 10.24 | JA |
| Flange JIS B 2220 RF 20k 15A (1/2") | 260 / 10.24 | JB |

| SMO Dimensions | mm | in |
|----------------|-------------|-------|
| A | 189 | 7.44 |
| B | 58 | 2.28 |
| H1 (SMO) | 358 | 14.09 |
| H2 | 286 | 11.26 |
| H3 | 265 | 10.43 |
| W | see page 15 | |

Material of Manifold and Seals (Wetted Part) The connection block/manifold is made of SS316L. Depending upon sensor temperature range, sensors are supplied with the following seal types as standard. For alternative seal options (e.g., FFKM seals for N1) please see Options Codes on page 19. Other seals on request.

| Temperature Range | SMO |
|-------------------|-------|
| N1 | FKM |
| NA | FVMQ |
| E2 | FFKM* |

Weights and Shipping Dimensions

- Weight for sensor with 1" 150# flanges: ~9 kg/19.8 lb
- Shipping carton size: ~50 x 50 x 50 cm (20 x 20 x 20 in)
- Gross weight with RHE28, packaging: ~15 kg/33.1 lb

*FFKM seals minimum temperature is -20 °C/-4 °F; p_{max} = 700 bar

Sealless design with flanged/hub process connections

Parallel tube / dual measurement path Order

Code: PFO

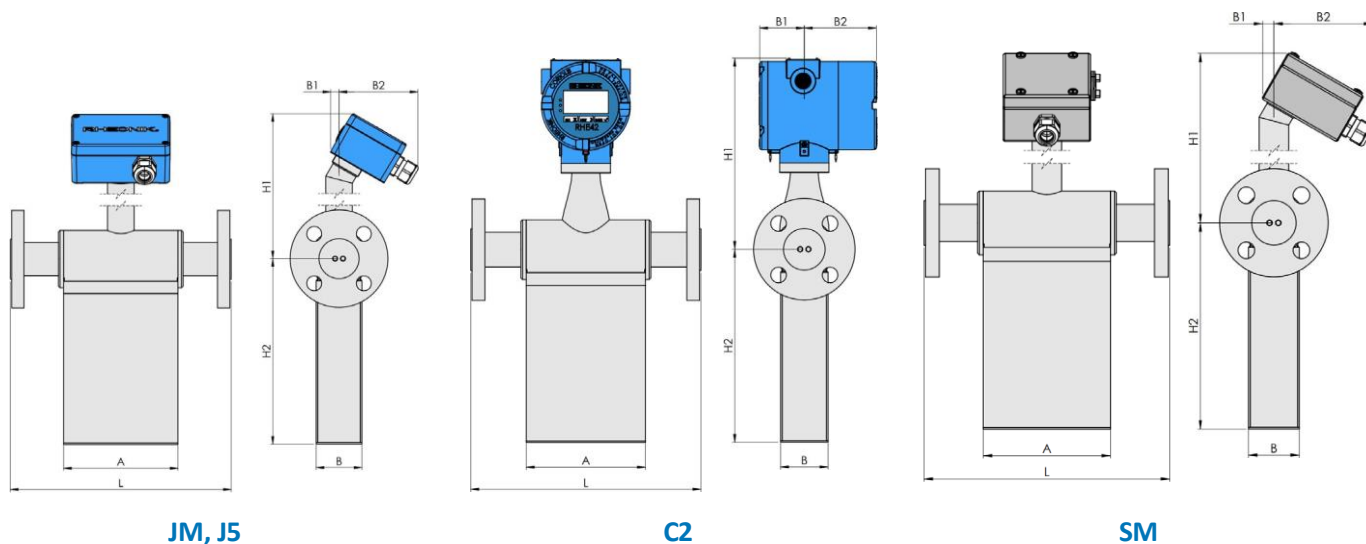

| PFO Process Connection | Dim. L mm / in | Order Code |
|-----------------------------------|----------------|------------|
| Flange ANSI 1" 150# RF/SF | 300 / 11.81 | A1 |
| Flange ANSI 1" 300# RF/SF | 300 / 11.81 | A2 |
| Flange ANSI 1" 600# RF/SF | 320 / 12.60 | A3 |
| Flange ANSI 1" 1500# RF/SF | 340 / 13.39 | A4 |
| Flange ANSI 1" 2500# RF/SF | 360 / 14.17 | A5 |
| Flange ANSI 1" 1500# RTJ | 340 / 13.39 | R1 |
| Flange ANSI 1" 2500# RTJ | 360 / 14.17 | R2 |
| Flange DIN DN25/PN40 Form B1 | 300 / 11.81 | D1 |
| Flange DIN DN25/PN100 Form B2 | 320 / 12.60 | D2 |
| Flange JIS B 2220 RF 10k 25A (1") | 300 / 11.81 | J1 |
| Flange JIS B 2220 RF 20k 25A (1") | 300 / 11.81 | J2 |
| Grayloc® Hub 1.5" GR11 | 360 / 14.17 | H1 |

For other hub connections (e.g. Destec, Galperti, Techlok) please consult factory

| PFO Dimensions | mm | in |
|----------------|-----|-------|
| A | 170 | 6.69 |
| B | 58 | 2.28 |
| H2 | 275 | 10.83 |
| B1 (JM, J5) | 11 | 0.43 |
| B2 (JM, J5) | 100 | 3.94 |
| H1 (JM, J5) | 197 | 7.76 |
| B1 (C2) | 55 | 2.17 |
| B2 (C2) | 88 | 3.46 |
| H1 (C2) | 234 | 9.21 |
| B1 (SM) | 13 | 0.51 |
| B2 (SM) | 113 | 4.45 |
| H1 (SM) | 192 | 7.56 |

Weights and Shipping Dimensions

- Weight for sensor with 1" 150# flanges: ~8 kg/17.6 lb
- Shipping carton size: ~50 x 50 x 50 cm (20 x 20 x 20 in)
- Gross weight with RHE28, packaging: ~14 kg/30.9 lb

Sealless design with threaded process connections

Parallel tube / dual measurement path Order

Code: PFT

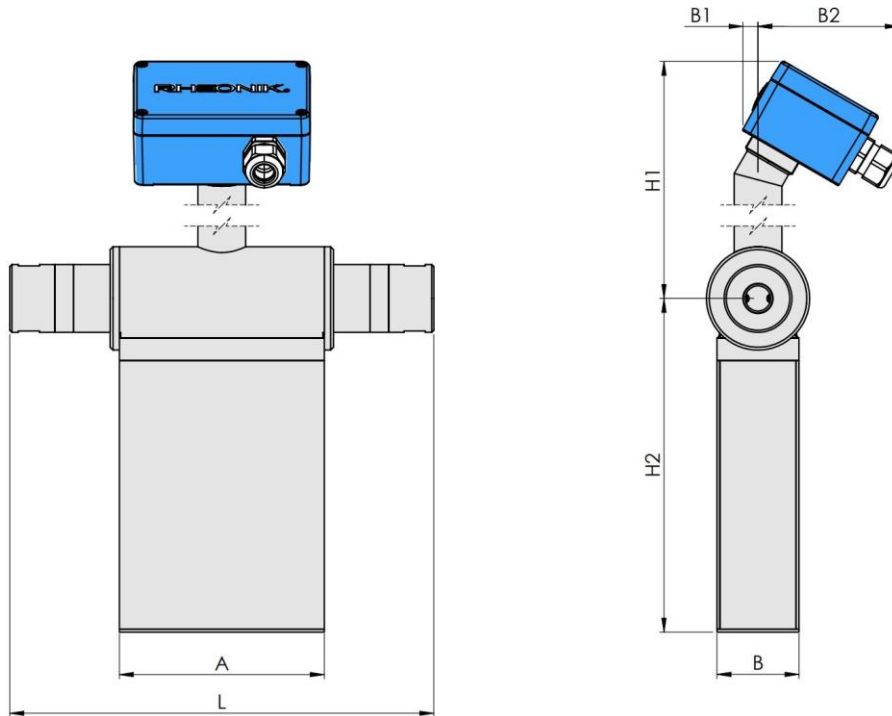

| PFT Process Connection | Dim. L mm / in | Order Code |
|---|----------------|------------|
| Female Thread G 1/2" | 325 / 12.80 | G1 |
| Female Thread 1/2" NPT | 325 / 12.80 | N1 |
| Autoclave 9/16" MP - 13/16" - 16 UN Female Thread | 325 / 12.80 | P2 |

| PFT Dimensions | mm | in |
|----------------|-----|-------|
| A | 170 | 6.69 |
| B | 58 | 2.28 |
| H2 | 275 | 10.83 |
| B1 (JM, J5) | 11 | 0.43 |
| B2 (JM, J5) | 100 | 3.94 |
| H1 (JM, J5) | 197 | 7.76 |
| B1 (C2) | 55 | 2.17 |
| B2 (C2) | 88 | 3.46 |
| H1 (C2) | 234 | 9.21 |
| B1 (SM) | 13 | 0.51 |
| B2 (SM) | 113 | 4.45 |
| H1 (SM) | 192 | 7.56 |

Weights and Shipping Dimensions

- Weight for sensor with threads:
~7.5 kg/16.5 lb
- Shipping carton size: ~50 x 50 x 50 cm (20 x 20 x 20 in)
- Gross weight with RHE28, packaging:
~13.5 kg/29.8 lb

Material and pressure rating of process connection:

Generally, the material of the connection is identical to the measurement tube material selected. Exception may occur, e.g., Swagelok is always SS316. The pressure rating for G thread connections is 540bar@120°C, 700bar@120°C for NPT.

Sealless design with flanged/hub and threaded process connections for E3/H4 temperature range

Parallel tube / dual measurement path Order Code: PFO/PFT

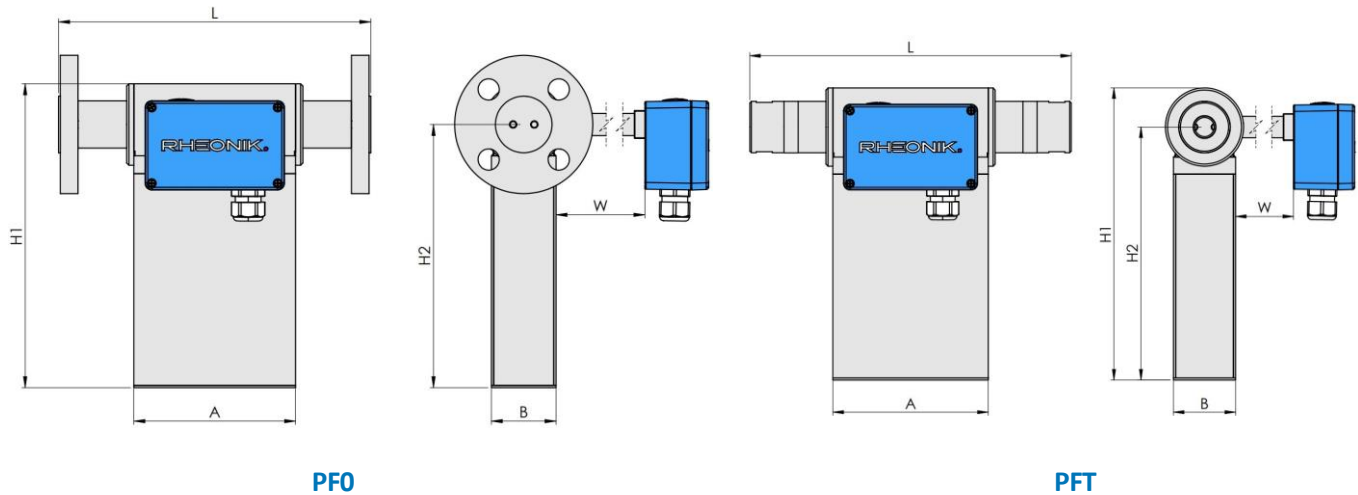

| PFO Process Connection | Dim. L mm / in | Order Code |
|-----------------------------------|----------------|------------|
| Flange ANSI 1" 150# RF/SF | 300 / 11.81 | A1 |
| Flange ANSI 1" 300# RF/SF | 300 / 11.81 | A2 |
| Flange ANSI 1" 600# RF/SF | 320 / 12.60 | A3 |
| Flange ANSI 1" 1500# RF/SF | 340 / 13.39 | A4 |
| Flange ANSI 1" 2500# RF/SF | 360 / 14.17 | A5 |
| Flange ANSI 1" 1500# RTJ | 340 / 13.39 | R1 |
| Flange ANSI 1" 2500# RTJ | 360 / 14.17 | R2 |
| Flange DIN DN25/PN40 Form B1 | 300 / 11.81 | D1 |
| Flange DIN DN25/PN100 Form B2 | 320 / 12.60 | D2 |
| Flange JIS B 2220 RF 10k 25A (1") | 300 / 11.81 | J1 |
| Flange JIS B 2220 RF 20k 25A (1") | 300 / 11.81 | J2 |
| Grayloc® Hub 1.5" GR11 | 360 / 14.17 | H1 |

For other hub connections (e.g. Destec, Galperti, Techlok) please consult factory

| PFT Process Connection | Dim. L mm / in | Order Code |
|---|----------------|------------|
| Female Thread G 1/2" | 325 / 12.80 | G1 |
| Female Thread 1/2" NPT | 325 / 12.80 | N1 |
| Autoclave 9/16" MP - 13/16" - 16 UN Female Thread | 325 / 12.80 | P2 |

| PFO/PFT E3/H4 Dimensions | mm | in |
|--------------------------|-------------|-------|
| A | 170 | 6.69 |
| B | 58 | 2.28 |
| H1 | 312 | 12.28 |
| H2 | 275 | 10.83 |
| W | see page 15 | |

Weights and Shipping Dimensions

- Weight for sensor with 1" 150# flanges: ~8 kg/17.6 lb
- Shipping carton size: ~50 x 50 x 50 cm (20 x 20 x 20 in)
- Gross weight with RHE28, packaging: ~14 kg/30.9 lb

Sealless design with threaded process connections

Parallel tube / dual measurement path Order

Code: PMT

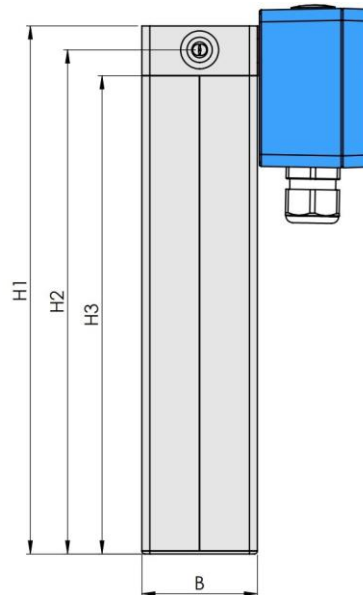
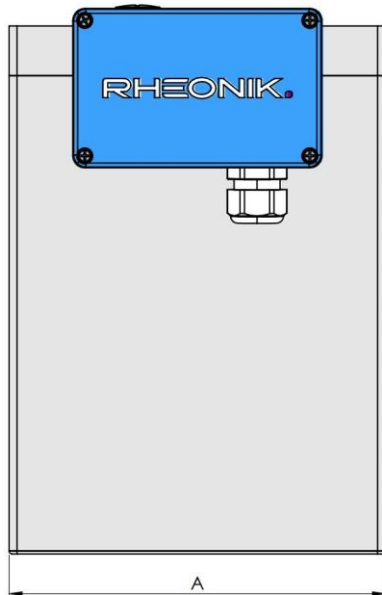

| PMT Process Connection | Dim. A mm / in | Order Code |
|---|----------------|------------|
| Autoclave 9/16" MP - 13/16" - 16 UN female thread | 189 / 7.44 | P2 |
| Autoclave 3/4" MP - 3/4" - 14 NPSM female thread | 189 / 7.44 | P3 |

| PMT Dimensions | mm | in |
|-------------------|-----|-------|
| A | 189 | 7.44 |
| B | 58 | 2.28 |
| H1 (P2 Autoclave) | 265 | 10.43 |
| H1 (P3 Autoclave) | 274 | 10.79 |
| H2 (P2 Autoclave) | 253 | 9.96 |
| H2 (P3 Autoclave) | 256 | 10.08 |
| H3 | 240 | 9.45 |

Weights and Shipping Dimensions

- Weight for sensor with threads: ~7.5 kg/16.5 lb
- Shipping carton size: ~50 x 50 x 50 cm (20 x 20 x 20 in)
- Gross weight with RHE28, packaging: ~13.5 kg/29.8 lb

Electrical Connection Options To Transmitters

Any Rheonik Mass Flow Transmitter model can be combined with any Rheonik Mass Flow Sensor to provide an overall mass flow measurement system to suit any requirement. Rheonik Coriolis transmitters are available in both integral and remote mounting styles. A range of connection options is available to suit all application requirements.

Order Code: JM
(J5 with RHE45 Integral Transmitter) Standard Coated Aluminum Terminal Box

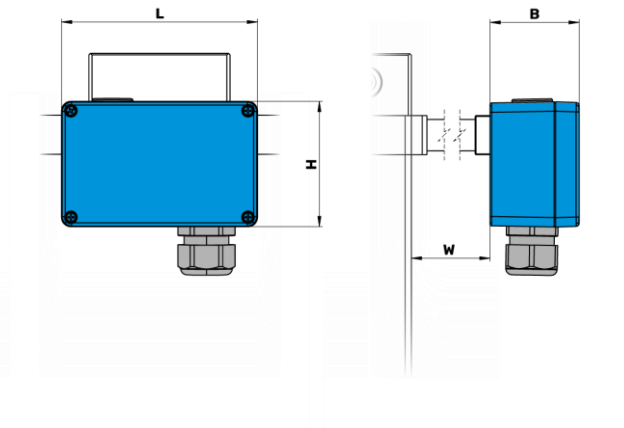

Order Code: PM
Compact Coated Aluminum Terminal Box

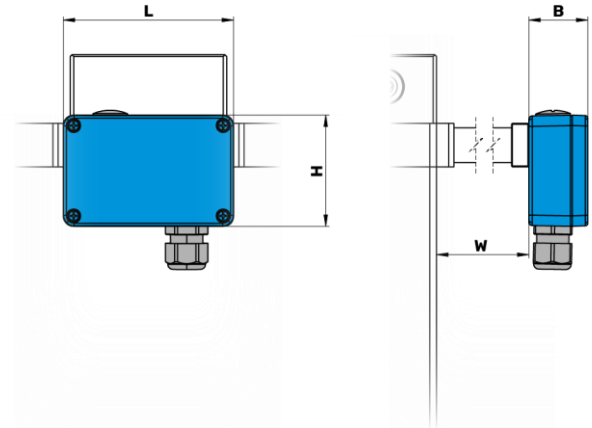

Order Code: SM
Terminal Box and Entire Enclosure in SS 316

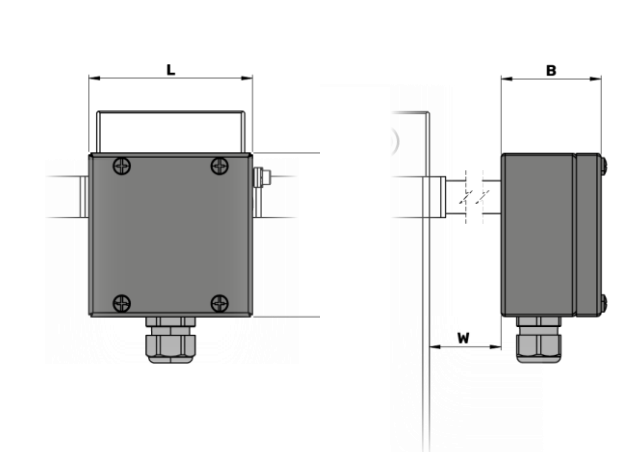

Order Code: TM
Integral PTFE Cable (No Terminal Box). Std. Length 2 m. Can be extended up to max 10 m

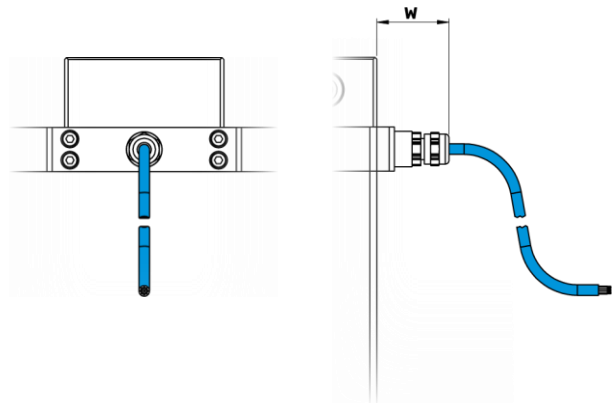

| Connection Option | Dimension | mm | in |
|--|-----------|----------------|--------------------|
| JM, J5 Terminal Box | L x H x B | 125 x 80 x 57 | 4.92 x 3.15 x 2.24 |
| PM Compact Terminal Box | L x H x B | 98 x 64 x 34 | 3.86 x 2.52 x 1.34 |
| SM SS316 Terminal Box | L x H x B | 100 x 100 x 61 | 3.94 x 3.94 x 2.40 |
| TM Integral PTFE Cable | W | 41 | 1.61 |
| JM, J5, PM, SM with Temperature Range N1, NA | W | 2 | 0.08 |
| JM, J5, PM, SM with Temperature Range E2, E3 | W | 100 | 3.94 |

JM, SM Terminal boxes are supplied with an M20 x 1.5 cable entry, optional entries available – see Separately Ordered Options, page 19 PM Compact Terminal boxes are supplied with an M16 x 1.5 cable entry
For details of the integral transmitter used with option J5, please see the RHE45 datasheet

Installation/Mounting Schemes

Recommended for sensitive, low flow installations (order codes see page 19 "Accessories")

Pipe Support Brackets

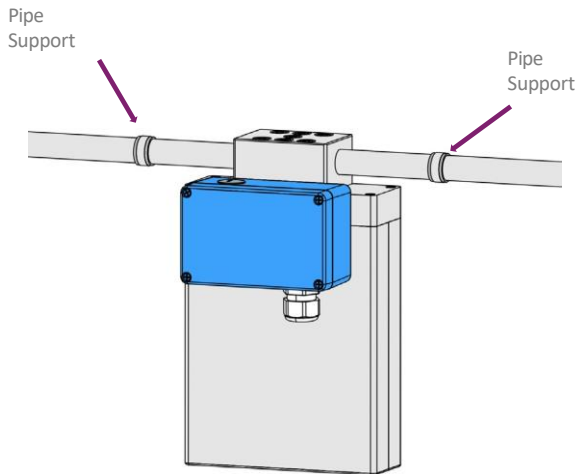

Sensor Mounting Holes (backside of the sensor)

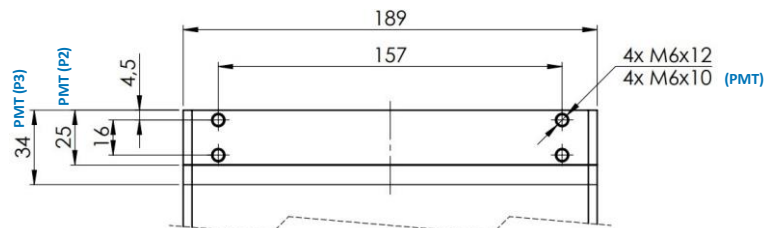

Thread dimensions ground plate PF0/PFT

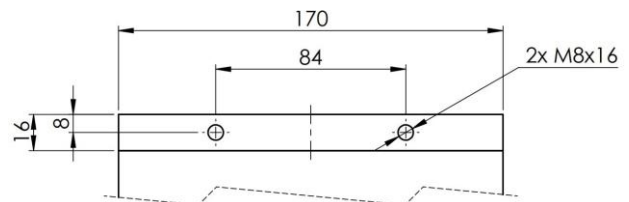

Wall Mounting Bracket Accessory

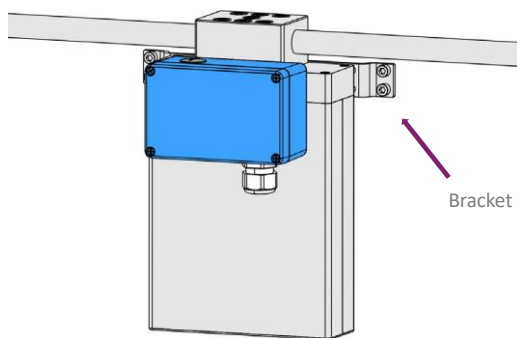

Floor Mounting "Foot" Bracket Accessory

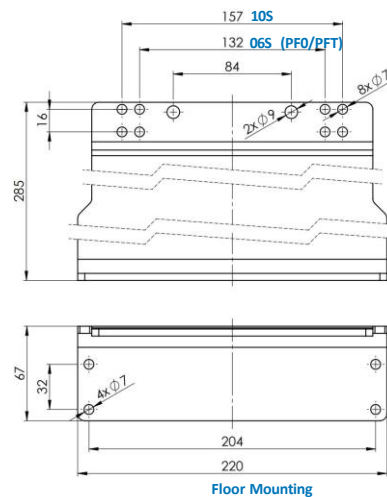
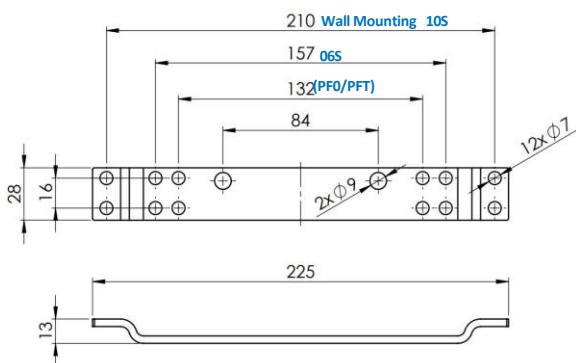
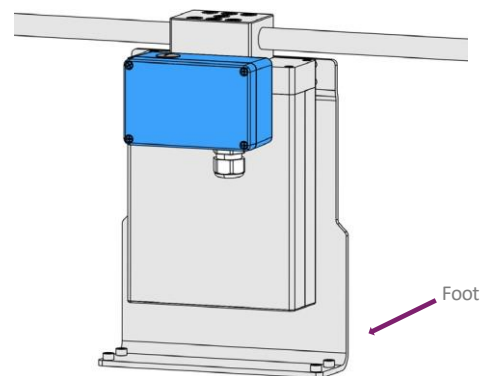

Electrical Connection to Transmitter Compatibility

Electrical connection option selections are compatible with the transmitter range according to the following table. Note that economical blind front versions of some transmitters are available where displays and keypads are not required. The wide range of Rheonik sensors and transmitters provide tremendous options for system designers and end users alike.

| Sensor Connection Options | |  |  |  |  |  |  |
|---|------------|---|---|---|--|---|---|
| | Order Code | JM | SM | TM | J5 | C2 | PM |
|  | RHE 21 | ✓ | ✓ | ✓ | — | — | ✓ |
|  | RHE 26 | ✓ | ✓ | ✓ | — | — | ✓ |
|  | RHE 27 | ✓ | ✓ | ✓ | — | — | ✓ |
|  | RHE 28 | ✓ | ✓ | ✓ | — | — | ✓ |
|  | RHE 42 | ✓ | ✓ | ✓ | — | ✓ | ✓ |
|  | RHE 45 | — | — | — | ✓ | — | — |
|  | RHE 46 | ✓ | ✓ | ✓ | — | — | ✓ |

Hazardous Area Certifications

| Order Code | Zone / Division | Approval | Labeling |
|------------|-----------------|---------------|--|
| A2 | Zone 2 | ATEX IECEX | Ex II 3G Ex ec IIC T6...T1 Gc Ex ec IIC T6...T1 Gc |
| A1 | Zone 1 | ATEX IECEX | Ex II 2G Ex ib IIC T6...T1 Gb Ex ib IIC T6...T1 Gb |
| A0 | Zone 0 | ATEX IECEX | Ex II 1G Ex ia IIC T6...T1 Ga Ex ia IIC T6...T1 Ga |
| C2 | Zone 2 | USA/Canada | Class I, Zone 2, AEx nA IIC T6...T1 Gc |
| C0 | Div 1, Zone 0 | USA/Canada | Class I, Div 1, Groups A, B, C and D T6...T1; Class I, Zone 0, AEx ia IIC T6...T1 Ga |



레오닉에 대해

레오닉의 목표는 최고의 Coriolis 질량유량계를 설계하고 제조하는 것입니다.

R&D 및 엔지니어링 팀은 효율적이고 정밀도가 뛰어난 새롭고 향상된 유량 솔루션을 제공하기 위해 전념하고 있으며, 생산 팀은 각각의 제품들에 대한 원자재 공급부터 제조, 운송까지 책임지고 서비스 및 지원 팀은 귀사에서 사용하는 모든 레오닉 제품을 분류, 통합, 시운전 및 유지 보수가 가능하도록 지원합니다.

레오닉 제품을 사용하신다면 귀사는 우리의 소중한 비즈니스 파트너입니다. 플랜트의 특별한 구성이 필요하다면 설치에 추가 비용이 발생하는 “표준” 제품 또는 광범위한 제품으로도 적합한 구성을 할 수 없는 경우에는 당사의 전용 “AnyPipeFit 실행”으로 어떠한 유량 센서의 크기 또는 프로세스 커넥션 타입이라도 귀사가 원하는 제품으로 “맞춤제작” 할 수 있습니다.

귀사의 주 제품으로 어떤 제어 시스템을 사용하든 당사의 AnyInterface 실행”으로 설치 및 통신에 문제가 없습니다. 레오닉 RHE 트랜스미터는 다양한 아날로그 또는 디지털 신호와 함께 모든 네트워크/bus 인터페이스 (HART, ProfibusDP, ProfiNet, EtherCAT, PowerLink, EtherNet/IP, CAN 등)를 제공합니다. 레오닉 RHE 트랜스미터는 귀사의 시스템에 (어려운 문제 및 변환이 필요 없이) 연결하여 사용 가능합니다.

(주)레오닉코리아
#07547
서울시 강서구 양천로 583
우림블루나인비즈니스센터
A동 1008호

www.rheonik.kr
info@rheonik.kr
02-3664-5015

