



## RHM 06

# Coriolis Mass Flow Meter for Batching/Filling and Accurate Measurement

General Flow Control / Additive Dosing / Mixing and Batching / Chemical Injection / Package and Container Filling





## 이점

- 유량 측정 범위 36 kg/min(79.37 lb/min)
- 압력 적용 범위 1,722 bar (24975.5 psi)
- 온도 적용 범위 -196 to +350°C (-320 to +662°F)
- 질량 유량 정밀도 0.05 %
- 재현성 0.05 %
- 40 시리즈 트랜스미터와 함께 사용시 4 kHz 측정 업데이트 및 10ms 미만의 응답 속도
- 100 g/min 미만까지 정확하게 측정
- 레오닉 **AnyPipeFit Commitment** 방법은 어떠한 프로세스 타입 및 사이즈에도 연결 가능하므로 설치 비용 절감
- Compact design 으로 최소 설치 공간 필요
- 방폭 인증 획득
- Stainless steel 외함 가능
- 일체형 및 분리형 트랜스미터 연결 가능

## RHM06 일반사양

<b>Nominal Flow (<math>Q_{nom}</math>)*</b>	25 kg/min (55.1 lb/min)
<b>Maximum Flow (<math>Q_{max}</math>)*</b>	36 kg/min (79.4 lb/min)
<b>Typical Minimum Flow (<math>Q_{min}</math>)*</b>	0.1 kg/min (0.22 lb/min)
<b>Serial Tube / Single Path</b>	Flow rates $Q_{max}$ , $Q_{nom}$ and $Q_{min}$ for "serial" sensors will be 50% of the above listed parallel/dual path version.
<b>Operating Temperature</b>	Fluid temperature range options cover from -196 °C to +350 °C (-320 °F to +662 °F) For integral transmitter versions please refer to transmitter datasheet
<b>Ambient Temperature</b>	-50 °C to +80 °C (-60 °F to +180 °F) (standard), versions available for installation in vacuum chamber (-260 °C / -430 °F) or oven (up to +210 °C / +410 °F) (optional)
<b>Pressure Ratings</b>	Up to 1722 bar / 24975 psi – dependent upon material
<b>Electrical Connection Sensor w/o Integral Transmitter</b>	M20 x 1.5 standard cable entry for JM, SM terminal box versions Optional entries available : ½" NPT or M25 x 1.5 (only for SM) or ¾" NPT (only for SM) M16 x 1.5 standard cable entry for PM terminal box version Max. cable length to remote RHE transmitter 100 m/330 ft
<b>Sensor Enclosure Materials</b>	Stainless steel 304 (standard), SS 316L (optional) Coated aluminum terminal box, SS 316L terminal box (optional)
<b>Enclosure Type</b>	Protection class IP66 (IP66 is mostly equivalent to NEMA4X) Optionally IP66-IP67 (IP67 declared by manufacturer, IP67 is mostly equivalent to NEMA 6)
<b>Wetted Materials</b>	Flow tubes SS 316L, SuperDuplex or Alloy C22 Manifolds SS 316L, seals FKM, FFKM, FVMQ, EPDM Standard flanges SS 316Ti, other connections SS 316L Additional/customer specific materials available upon request
<b>Process Connections</b>	Nearly any - The Rheonik <b>AnyPipeFit Commitment</b> covers a wide range of process connections types and sizes. Consult factory for types/sizes not listed in this data sheet on the Mechanical Construction pages
<b>Pressure Rating Compliance</b>	PED 2014/68/EU Article 4, Section 3 (SEP)
<b>Certifications and Approvals</b>	ATEX / IECEx Approvals Zone 0, 1, 2 (details see page 19) North American Approvals Cl. I, Div. 1, 2, Gr. A, B, C, D, Zone 0, 1, 2 OIML, MID custody transfer approval American Bureau of Shipping (ABS) DNV approval for marine applications
<b>Testing and Inspection</b>	All sensors are hydro tested, calibrated and supplied with a traceable calibration certificate. Customized calibration and testing services are available
<b>Project Documentation and QA, Services</b>	Rheonik offers a full set of services for large and complex engineering projects. Typical services offered are, but not limited to: <ul style="list-style-type: none"> <li>• Certificates of origin and conformity, mill certificates</li> <li>• Data books including WPS-WPQR, WPQ, NDT, test &amp; quality plans, functional testing, calibration procedures, customized packing, factory acceptance etc.</li> <li>• Painting to project specification</li> <li>• Start up and commissioning services on/offshore</li> </ul>
<b>Options</b>	Customization services for machine integration. Consult factory

\* At  $Q_{nom}$  pressure drop across a parallel tube sensor will be approximately 2 bar (29 psi) for H<sub>2</sub>O. Sensors can be operated at higher flow rates up to  $Q_{max}$  but pressure drop will be higher. Typical Minimum Flow  $Q_{min}$  is the recommended lowest flow rate for an accurate measurement. Sensors will measure flow rates lower than  $Q_{min}$  but uncertainty will increase beyond 1 % of rate.

The flow rate specifications above relate to standard pressure, parallel tube, manifold sensor versions. Models with higher pressure ratings have increased wall thickness and will have higher pressure drops.

## Calibration Options

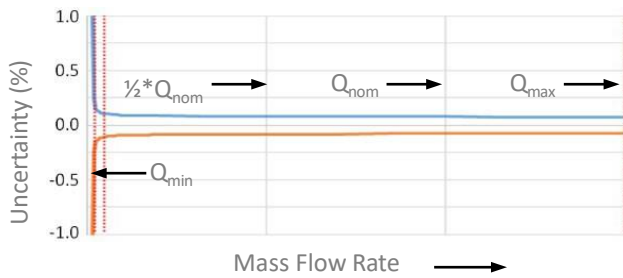

Order Code	General Accuracy Calibration
A	Standard - 0.20 % Uncertainty
B	Premium - 0.15 % Uncertainty

Order Code	High Accuracy Calibration
G	Premium Plus - 0.10 % Uncertainty
U	Ultimate - 0.05 % Uncertainty <i>Requires RHE 40 Series transmitter</i>

Order Code	Focused Calibration
1	0.10 % Low Flow Calibration* <i>Requires RHE 40 Series transmitter</i>
X	Customized Calibration** Consult factory

\* Low flow calibration focuses on the range from  $\frac{1}{2} * Q_{nom}$  downwards to lower flow rates than on other calibrations. Often used for low pressure gas or very viscous liquids

\*\* Customized calibration uses specific calibration points according to customer requirements

Reference conditions:  
18-24°C Water @ 1-3 bar

Order Code	Density Calibration / Performance (Liquid)
N	No Density Calibration
S	Standard $\pm 0.001$ kg/l Uncertainty
D	Enhanced $\pm 0.0005$ kg/l Uncertainty Requires High Accuracy or Focused Calibration Option

### Uncertainties and flow measurement turn-down

The turn down capability from  $Q_{nom}$  of the flow sensor is driven mainly by its zero point stability. At the very low end of the measuring range the uncertainty (u) is dominated by zero point stability.

- Zero point stability of a standard sensor with General Accuracy Calibration is:  $0.00086$  kg/min (0.0019 lbs/min).
- Zero point stability of a Gold Line sensor with High Accuracy or Focused Calibration is  $0.00058$  kg/min (0.00128 lbs/min).
- For flow  $Q \geq ZP$  stability / (Base Calibration uncertainty/100)  $\rightarrow u =$  calibration uncertainty
- For flow  $Q < ZP$  stability / (Base Calibration uncertainty/100)  $\rightarrow u =$  (zero stability/Q) \* 100

### Uncertainties from environmental and process conditions

If sensors are not zeroed at operating conditions, minor additional uncertainties can arise from elevated temperatures and pressures:

- $\pm 0.001074$  % of maximum flow per °C
- $\pm 0.000857$  % of maximum flow per bar.

Process temperature effect on density:

- Additional uncertainty of  $\pm 0.000064$  g/cm<sup>3</sup> per °C difference from calibration temperature with standard density calibration
- Additional uncertainty of  $\pm 0.000054$  g/cm<sup>3</sup> per °C difference from calibration temperature with enhanced density calibration.
- This effect can be mitigated by a simple field density adjustment at operating conditions.

Process pressure effect on mass flow:

The effect of pressure on flow measurement is 0.0001 % of rate per bar. Compensation is possible by pressure sensor input (analog input or digital write) or manual value entry into the transmitter.

Process pressure effect on density:

- The effect of pressure on density measurement is 0.00007 g/cm<sup>3</sup> per bar. Compensation is possible by pressure sensor input (analog input or digital write) or manual value entry into the transmitter.

*Premium Plus, Ultimate, Low Flow and Enhanced Density Calibration are only available in SS316L material, P1 lower pressure and N1 temperature range.*

*Applying Premium Plus calibration to higher pressure, special materials and/or non-standard temperature models will show higher zero uncertainties (up to 3 times higher than standard sensor).*

### Flow Measurement Repeatability

Standard Sensors  $\pm 0.1$  % of rate Gold Line Sensors  $\pm 0.05$  % of rate

### Temperature Measurement

Better than  $\pm 1$  °C

## Pressure Drop

Every Coriolis flow sensor generates pressure drop across its inlet and outlet when in use. The amount of pressure drop generated is mainly a function of the flow velocity within its tubes and the flowing viscosity of the stream.

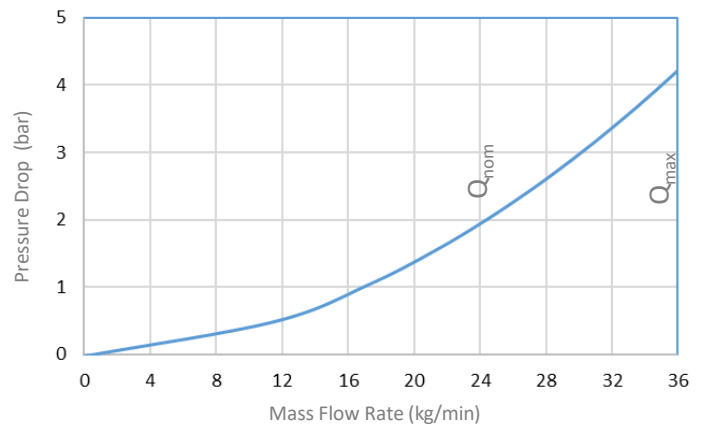

0 – 36 kg/min water, sensor with P1 pressure rating. Higher viscosities create higher pressure drop

## Measurement Tube Materials and Pressure Ratings

The maximum pressure ( $p_{max}$ ) of a sensor is determined by its lowest rated part. The lowest rated part can be either the measurement tube ( $p_{max}$  see table to the right), the connection block/manifold ( $p_{max}$  indicated in the Mechanical Construction section) or the process connection (for  $p_{max}$  see published standards or manufacturer information).

**Note:**

The material of the connection block/manifold is always SS 316L.

The material of the process connection of sealless sensor versions is usually the same as the measurement loops, however, could be different in special cases on PFT.

Order Code	Material	50°C / 122°F	120°C / 248°F	210°C / 410°F	350°C / 662°F
P1	SS 316L (standard)	213 3089	189 2741	160 2321	136 1972
P1	Alloy C22	300 4351	267 3872	227 3292	189 2741
P2	SS 316L (standard)	580 8412	516 7484	435 6309	370 5366
P2	SuperDuplex*	580 8412	516 7484	435 6309	N/A
P3	SuperDuplex*	910 13198	847 12285	760 11023	N/A
P4	SuperDuplex*	1234 17898	1149 16665	1030 14939	N/A
P5	SuperDuplex*	1722 24975	1603 23249	1438 20856	N/A

\* Note minimum operating temperature for SuperDuplex stainless steel is -40 °C Units: bar / psi

### Other Materials

Other wetted materials may be possible for chemical compatibility, lower pressure drop, abrasion allowance, other application specific requirements. Rheonik can provide nearly any material for the wetted parts.

Contact factory with specification for assessment and availability.

## Mechanical Construction

Sensors are manufactured with two internal measurement tubes arranged side by side. In parallel or dual measurement path sensors (order code Pxx), these tubes are connected in parallel, and the flowing fluid is split equally between them. In serial or single measurement path sensors (order code Sxx), the internal tubes are connected end to end, creating a single path through which all fluid flows. Manifold designs have a removable inlet/outlet block/manifold and utilize seals between the manifold and sensor body. In sealless designs, the measurement tubes are continuous between the process connections and do not have seals. Manifold designs typically offer shorter delivery lead times and may have a lower pressure drop than sealless designs for the same flow rate.

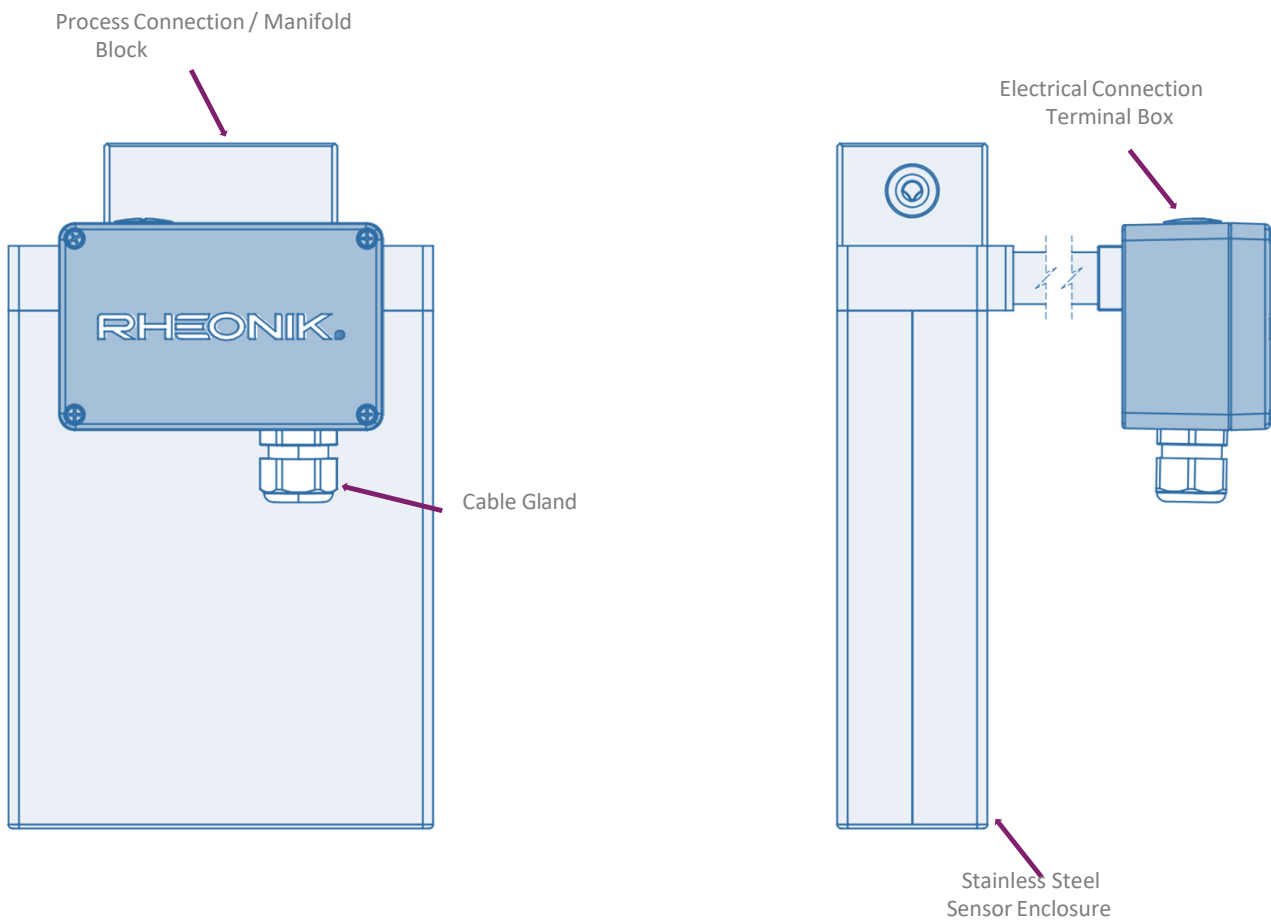

### Note

All dimensions in the following pages are for standard design products. For customization of face-to-face length and/or process connection types other than the ones listed on the following page, please consult factory. Note that larger diameter flange process connections are always possible. The tolerance of the process connections is  $\pm 2$  mm.

**Manifold design with threaded process connections**

Parallel tube / dual measurement path

Order Codes: PM0/PH0

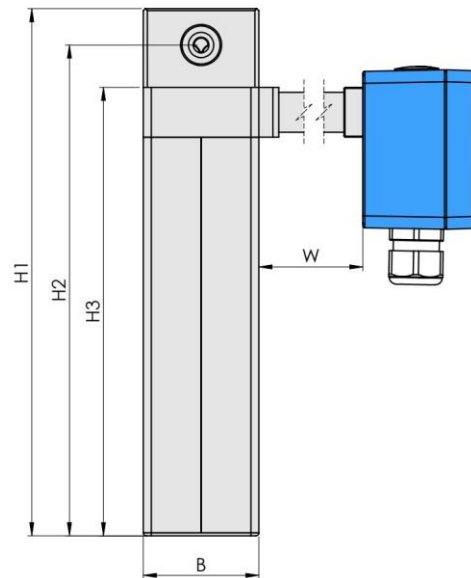
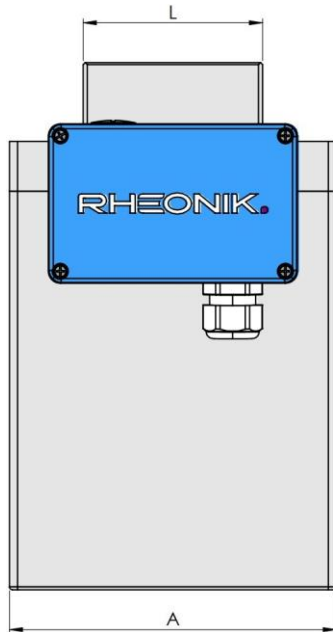

PM0 / PH0 Process Connection	Dim. L mm / in	Order Code
Female Thread G 1/2" - PM0	80 / 3.15	G1
Female Thread 1/2" NPT- PM0	80 / 3.15	N1
Autoclave 9/16" MP - 13/16" - 16 UN Female Thread - only PH0	90 / 3.54	P2

**Manifold Pressure Ratings @ 120 °C / 248 °F**

PM0 – 700 bar / 10150 psi

PH0 – 1220 bar / 17695 psi (20000 psi @ 50 °C / 122 °F)

PM0 / PH0 Dimensions	mm	in
A	164	6.46
B	58	2.28
H1 (PM0, PH0)	265	10.43
H2	246	9.69
H3	225	8.86
W	see page 14	

**Weights and Shipping Dimensions**

- Weight for sensor with threads:  
~6 kg/13.2 lb
- Shipping carton size: ~50 x 50 x 50 cm (20 x 20 x 20 in)
- Gross weight with RHE 28, packaging:  
~12 kg/26.5 lb

**Material of Manifold and Seals (Wetted Part)**

The connection block/manifold is made of SS316L.

Depending upon sensor temperature range, sensors are supplied with the following seal types as standard. For alternative seal options (e.g., FFKM seals for N1) please see Options Codes on page 18. Other seals on request.

Temperature Range	PM0	PH0
N1	FKM	FKM
NA	FVMQ	FVMQ
E2	FFKM*	n/a

\*FFKM seals minimum temperature is -20 °C/-4 °F; p<sub>max</sub> = 700 bar

**Manifold design with threaded process connections**

Serial tube / single measurement path Order

Codes: SM0

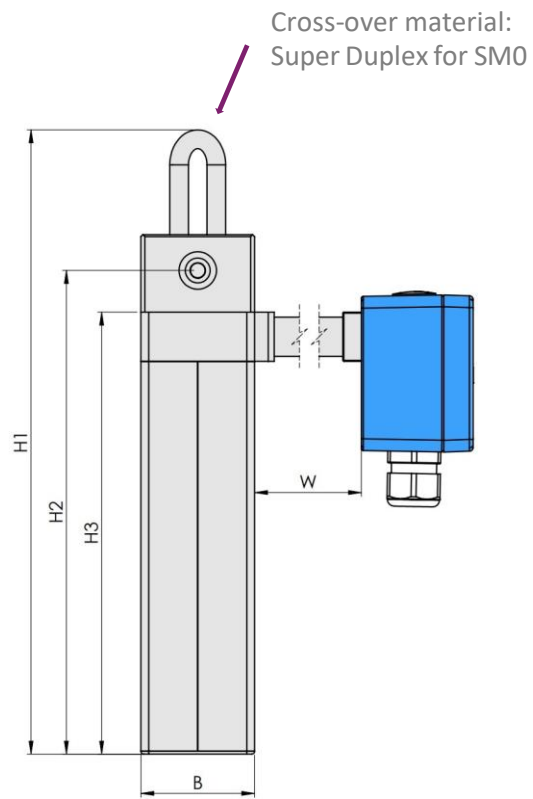
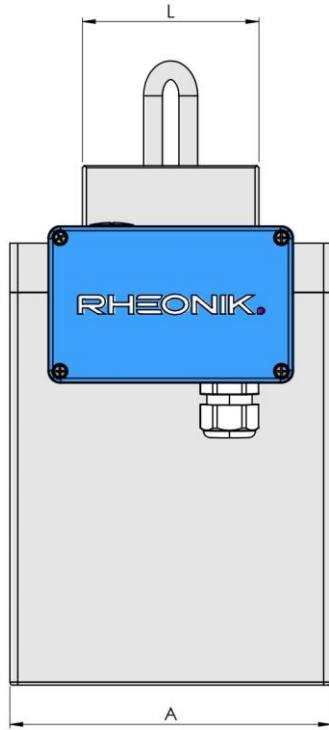

SM0 Process Connection	Dim. L mm / in	Order Code
Female Thread G ½"- SM0	90 / 3.54	G1
Female Thread ½" NPT- SM0	90 / 3.54	N1

SM0 Dimensions	mm	in
A	164	6.46
B	58	2.28
H1	318	12.52
H2	246	9.69
H3	225	8.86
W	see page 14	

**Manifold Pressure Ratings @ 120 °C / 248 °F**

SM0 – 700 bar / 10150 psi

**Weights and Shipping Dimensions**

- Weight for sensor with threads:  
~6 kg/13.2 lb
- Shipping carton size: ~50 x 50 x 50 cm (20 x 20 x 20 in)
- Gross weight with RHE 28, packaging:  
~12 kg/26.5 lb

**Material of Manifold and Seals (Wetted Part)**

The connection block/manifold is made of SS316L. Depending upon sensor temperature range, sensors are supplied with the following seal types as standard. For alternative seal options (e.g., FFKM seals for N1) please see Options Codes on page 18. Other seals on request.

Temperature Range	SM0	SH0
N1	FKM	FKM
NA	FVMQ	FVMQ
E2	FFKM*	n/a

\*FFKM seals minimum temperature is -20 °C/-4 °F; p<sub>max</sub> = 700 bar

### Manifold design with flanged process connections

Parallel tube / dual measurement path

Order Code: PMO

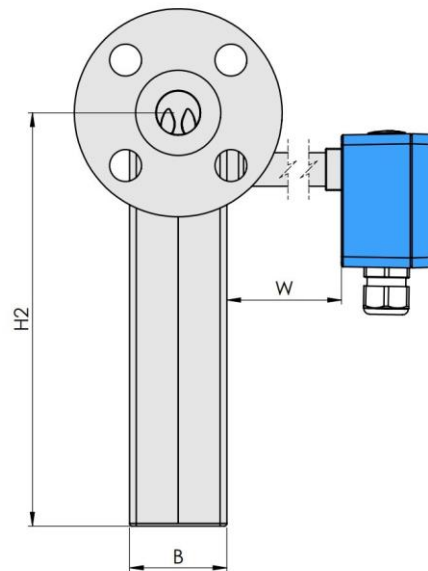
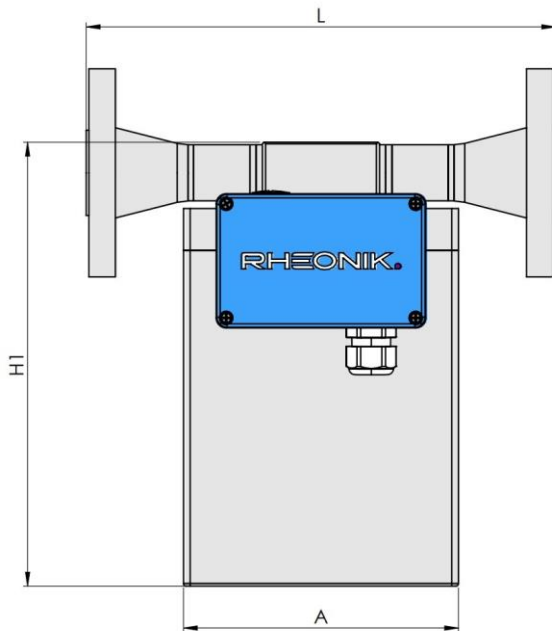

PMO Process Connection	Dim. L mm / in	Order Code
<b>Standard</b>		
Flange ANSI 1" 150# RF/SF	280 / 11.02	A1
Flange ANSI 1" 300# RF/SF	280 / 11.02	A2
Flange ANSI 1" 600# RF/SF	300 / 11.81	A3
Flange ANSI 1" 1500# RF/SF	340 / 13.39	A4
Flange ANSI 1" 1500# RTJ	340 / 13.39	R1
Flange DIN DN25/PN40 Form B1	280 / 11.02	D1
Flange DIN DN25/PN100 Form B2	300 / 11.81	D2
Flange JIS B 2220 RF 10k 25A (1")	280 / 11.02	J1
Flange JIS B 2220 RF 20k 25A (1")	280 / 11.02	J2
<b>Non-Standard (longer lead times, extra price)</b>		
Flange ANSI ½" 150# RF/SF	260 / 10.24	AA
Flange ANSI ½" 300# RF/SF	260 / 10.24	AB
Flange ANSI ½" 600# RF/SF	280 / 11.02	AC
Flange ANSI ½" 1500# RTJ	320 / 12.60	RA
Flange DIN DN15/PN40 Form B1	280 / 11.02	DA
Flange DIN DN15/PN100 Form B2	280 / 11.02	DB
Flange JIS B 2220 RF 10k 15A (1/2")	260 / 10.24	JA
Flange JIS B 2220 RF 20k 15A (1/2")	260 / 10.24	JB

### Weights and Shipping Dimensions

- Weight for sensor with 1" 150# flanges: ~8 kg/17.6 lb

- Shipping carton size: ~50 x 50 x 50 cm (20 x 20 x 20 in)
- Gross weight with RHE 28, packaging: ~14 kg/30.9 lb

PMO Dimensions	mm	in
A	164	6.46
B	58	2.28
H1	265	10.43
H2	246	9.69
W	see page 14	

### Material of Manifold and Seals (Wetted Part)

The connection block/manifold is made of SS316L. Depending upon sensor temperature range, sensors are supplied with the following seal types as standard. For alternative seal options (e.g., FFKM seals for N1) please see Options Codes on page 18. Other seals on request.

Temperature Range	PMO
N1	FKM
NA	FVMQ
*FFKM seals minimum temperature is -20 °C/-4 °F; p FFKM* 700 bar	

**Manifold design with flanged process connections**

Serial tube / single measurement path Order

Code: SM0

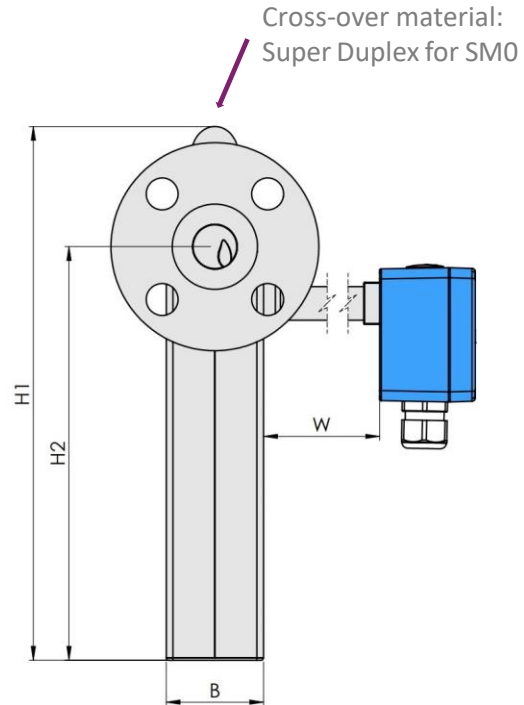
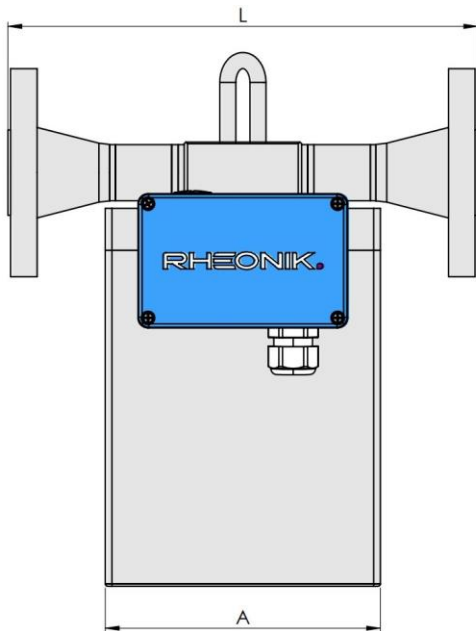

SMO Process Connection	Dim. L mm / in	Order Code
<b>Standard</b>		
Flange ANSI 1" 150# RF/SF	280 / 11.02	A1
Flange ANSI 1" 300# RF/SF	280 / 11.02	A2
Flange ANSI 1" 600# RF/SF	300 / 11.81	A3
Flange ANSI 1" 1500# RF/SF	340 / 13.39	A4
Flange ANSI 1" 1500# RTJ	340 / 13.39	R1
Flange DIN DN25/PN40 Form B1	280 / 11.02	D1
Flange DIN DN25/PN100 Form B2	300 / 11.81	D2
Flange JIS B 2220 RF 10k 25A (1")	280 / 11.02	J1
Flange JIS B 2220 RF 20k 25A (1")	280 / 11.02	J2
<b>Non-Standard (longer lead times, extra price)</b>		
Flange ANSI 1/2" 150# RF/SF	260 / 10.24	AA
Flange ANSI 1/2" 300# RF/SF	260 / 10.24	AB
Flange ANSI 1/2" 600# RF/SF	280 / 11.02	AC
Flange ANSI 1/2" 1500# RTJ	320 / 12.60	RA
Flange DIN DN15/PN40 Form B1	280 / 11.02	DA
Flange DIN DN15/PN100 Form B2	280 / 11.02	DB
Flange JIS B 2220 RF 10k 15A (1/2")	260 / 10.24	JA
Flange JIS B 2220 RF 20k 15A (1/2")	260 / 10.24	JB

**Weights and Shipping Dimensions**

- Weight for sensor with 1" 150# flanges: ~8 kg/17.6 lb

SMO Dimensions	mm	in
A	164	6.46
B	58	2.28
H1	318	12.52
H2	246	9.69
W	see page 14	

**Material of Manifold and Seals (Wetted Part)**

The connection block/manifold is made of SS316L. Depending upon sensor temperature range, sensors are supplied with the following seal types as standard. For alternative seal options (e.g., FFKM seals for N1) please see Options Codes on page 18. Other seals on request.

Temperature Range	SMO
N1	FKM
NA	FVMQ

\*FFKM seals minimum temperature is -20 °C/-4 °F; p<sub>max</sub> = 70 bar

- Shipping carton size: ~50 x 50 x 50 cm (20 x 20 x 20 in)
- Gross weight with RHE 28, packaging: ~14 kg/30.9 lb

**Sealless design with flanged/hub process connections**

Parallel tube / dual measurement path

Order Code: PF0

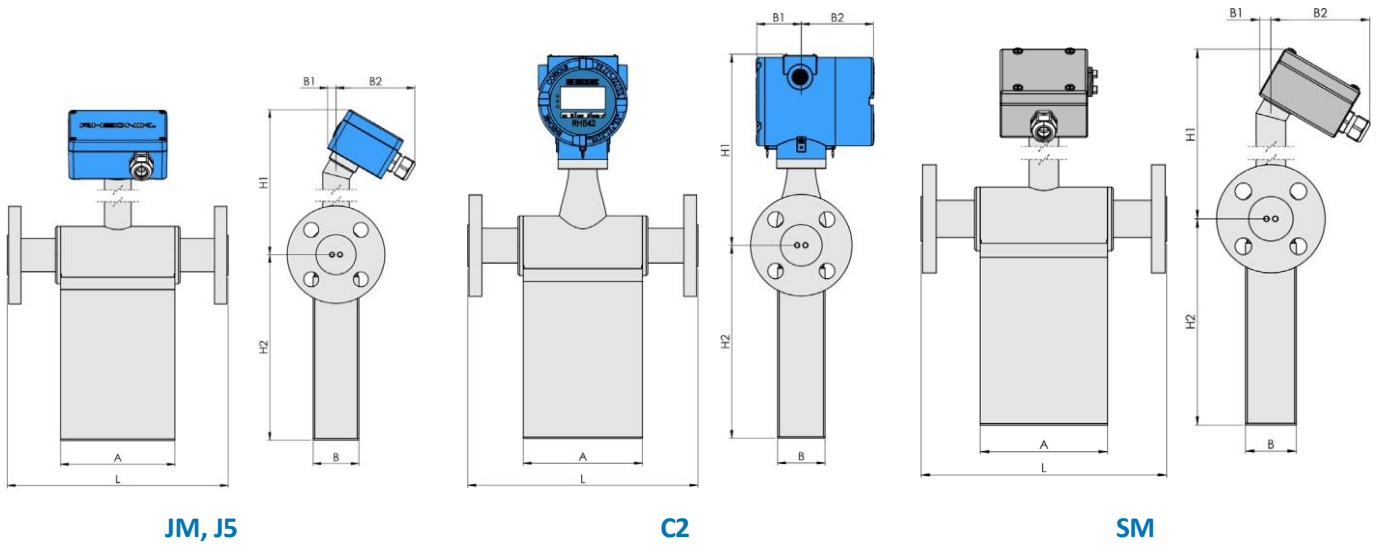

PF0 Process Connection	Dim. L mm / in	Order Code
Flange ANSI 1" 150# RF/SF	280 / 11.02	A1
Flange ANSI 1" 300# RF/SF	280 / 11.02	A2
Flange ANSI 1" 600# RF/SF	280 / 11.02	A3
Flange ANSI 1" 1500# RF/SF	320 / 12.60	A4
Flange ANSI 1" 1500# RTJ	320 / 12.60	R1
Flange ANSI 1" 2500# RTJ	320 / 12.60	R2
Flange DIN DN25/PN40 Form B1	280 / 11.02	D1
Flange DIN DN25/PN100 Form B2	300 / 11.81	D2
Flange JIS B 2220 RF 10k 25A (1")	280 / 11.02	J1
Flange JIS B 2220 RF 20k 25A (1")	280 / 11.02	J2
Grayloc® Hub 1" GR5 - only Type_F0	300 / 11.81	H1

For other hub connections (e.g. Destec, Galperti, Techlok) please consult factory

PF0 Dimensions	mm	in
A	145	5.71
B	58	2.28
H2	236	9.29
B1 (JM, J5)	11	0.43
B2 (JM, J5)	100	3.94
H1 (JM, J5)	197	7.76
B1 (C2)	55	2.17
B2 (C2)	88	3.46
H1 (C2)	234	9.21
B1 (SM)	13	0.51
B2 (SM)	113	4.45
H1 (SM)	192	7.56

**Weights and Shipping Dimensions**

- Weight for sensor with 1" 150# flanges: ~7 kg/15.4 lb
- Shipping carton size: ~50 x 50 x 50 cm (20 x 20 x 20 in)
- Gross weight with RHE 28, packaging: ~13 kg/28.7 lb

### Sealless design with threaded process connections

Parallel tube / dual measurement path

Order Code: PFT

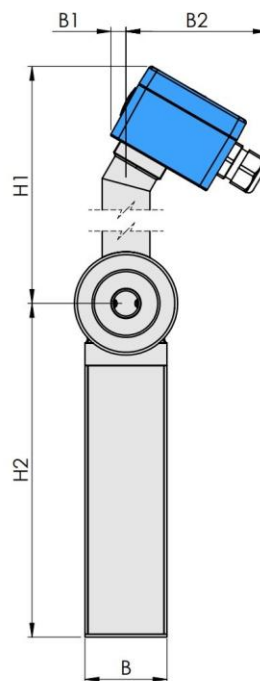
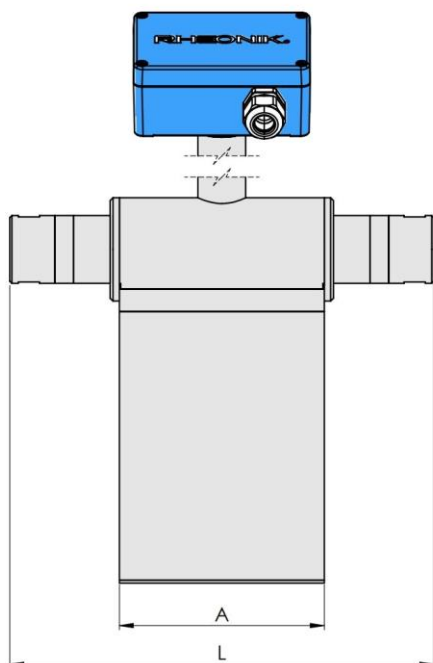

PFT Process Connection	Dim. L mm / in	Order Code
Female Thread G 1/2"	300 / 11.81	G1
Female Thread 1/2" NPT	300 / 11.81	N1
Autoclave 9/16" MP - 13/16" - 16 UN Female Thread	300 / 11.81	P2

PFT Dimensions	mm	in
A	145	5.71
B	58	2.28
H2	236	9.29
B1 (JM, J5)	11	0.43
B2 (JM, J5)	100	3.94
H1 (JM, J5)	197	7.76
B1 (C2)	55	2.17
B2 (C2)	88	3.46
H1 (C2)	234	9.21
B1 (SM)	13	0.51
B2 (SM)	113	4.45
H1 (SM)	192	7.56

### Weights and Shipping Dimensions

- Weight for sensor with threads:  
~6.5 kg/14.3 lb
- Shipping carton size: ~50 x 50 x 50 cm (20 x 20 x 20 in)
- Gross weight with RHE 28, packaging:  
~12.5 kg/27.6 lb

### Material and pressure rating of process connection:

Generally, the material of the connection is identical to the measurement tube material selected.

Exception may occur, e.g., Swagelok is always SS316. The pressure rating for G thread is 540bar@120°C, 700bar@120°C for NPT.

**Sealless design with flanged/hub and threaded process connections for E3/H4 temperature range**

Parallel tube / dual measurement path

Order Code: PF0/PFT

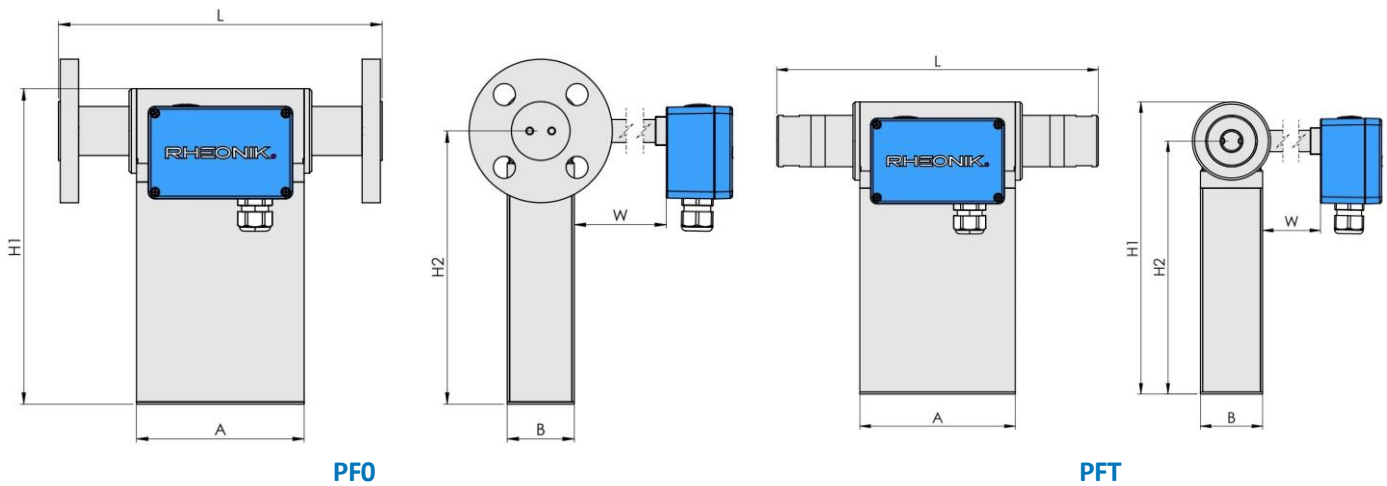

PF0 Process Connection	Dim. L mm / in	Order Code
Flange ANSI 1" 150# RF/SF	280 / 11.02	A1
Flange ANSI 1" 300# RF/SF	280 / 11.02	A2
Flange ANSI 1" 600# RF/SF	280 / 11.02	A3
Flange ANSI 1" 1500# RF/SF	320 / 12.60	A4
Flange ANSI 1" 1500# RTJ	320 / 12.60	R1
Flange ANSI 1" 2500# RTJ	320 / 12.60	R2
Flange DIN DN25/PN40 Form B1	280 / 11.02	D1
Flange DIN DN25/PN100 Form B2	300 / 11.81	D2
Flange JIS B 2220 RF 10k 25A (1")	280 / 11.02	J1
Flange JIS B 2220 RF 20k 25A (1")	280 / 11.02	J2
Grayloc® Hub 1" GR5 - only Type_F0	300 / 11.81	H1

For other hub connections (e.g. Destec, Galperti, Techlok) please consult factory

PFT Process Connection	Dim. L mm / in	Order Code
Female Thread G 1/2"	300 / 11.81	G1
Female Thread 1/2" NPT	300 / 11.81	N1
Autoclave 9/16" MP - 13/16" - 16 UN Female Thread	300 / 11.81	P2

PF0/PFT E3/H4 Dimensions	mm	in
A	145	5.71
B	58	2.28
H1	273	10.75
H2	236	9.29
W	see page 14	

**Weights and Shipping Dimensions**

- Weight for sensor with 1" 150# flanges: ~7 kg/15.4 lb
- Shipping carton size: ~50 x 50 x 50 cm (20 x 20 x 20 in)
- Gross weight with RHE 28, packaging: ~13 kg/28.7 lb

### Electrical Connection Options To Transmitters

Any Rheonik Mass Flow Transmitter model can be combined with any Rheonik Mass Flow Sensor to provide an overall mass flow measurement system to suit any requirement. Rheonik Coriolis transmitters are available in both integral and remote mounting styles. A range of connection options is available to suit all application requirements.

Order Code: JM  
(J5 with RHE45 Integral Transmitter) Standard Coated Aluminum Terminal Box

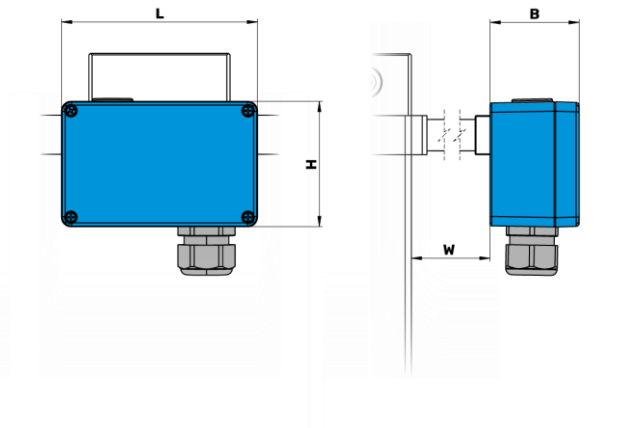

Order Code: PM  
Compact Coated Aluminum Terminal Box

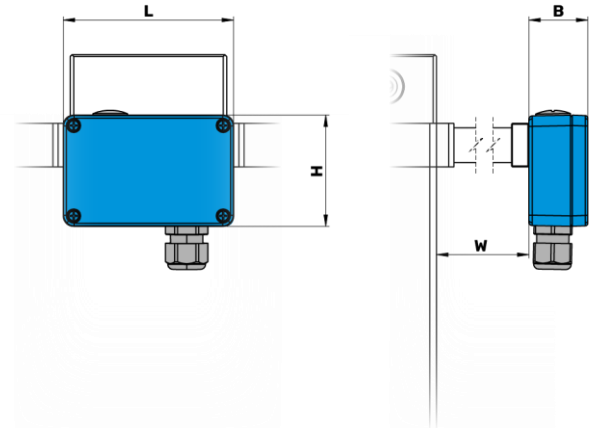

Order Code: SM  
Terminal Box and Entire Enclosure in SS 316L/Ti

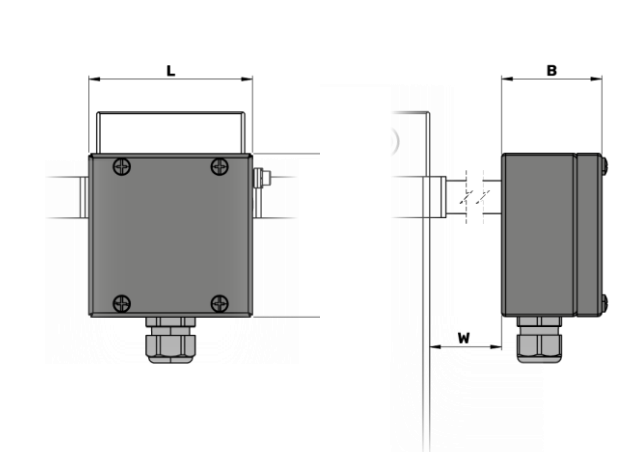

Order Code: TM  
Integral PTFE Cable (No Terminal Box). Std. Length 2 m. Can be extended up to max 10 m

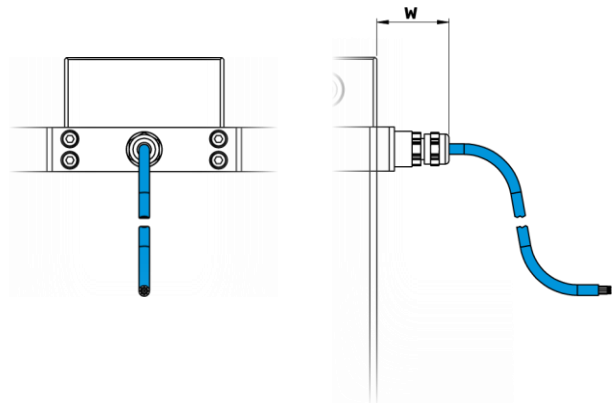

Connection Option	Dimension	mm	in
JM, J5 Terminal Box	L x H x B	125 x 80 x 57	4.92 x 3.15 x 2.24
PM Compact Terminal Box	L x H x B	98 x 64 x 34	3.86 x 2.52 x 1.34
SM SS316L Terminal Box	L x H x B	100 x 100 x 61	3.94 x 3.94 x 2.40
TM Integral PTFE Cable	W	41	1.61
JM, J5, PM, SM with Temperature Range N1, NA	W	2	0.08
JM, J5, PM, SM with Temperature Range E2, E3	W	100	3.94

JM, SM Terminal boxes are supplied with an M20 x 1.5 cable entry, optional entries available – see Separately Ordered Options, page 18 PM Compact Terminal boxes are supplied with an M16 x 1.5 cable entry  
For details of the integral transmitter used with option J5, please see the RHE45 datasheet

## Installation/Mounting Schemes

Recommended for sensitive, low flow installations (order codes see page 18 "Accessories")

### Pipe Support Brackets

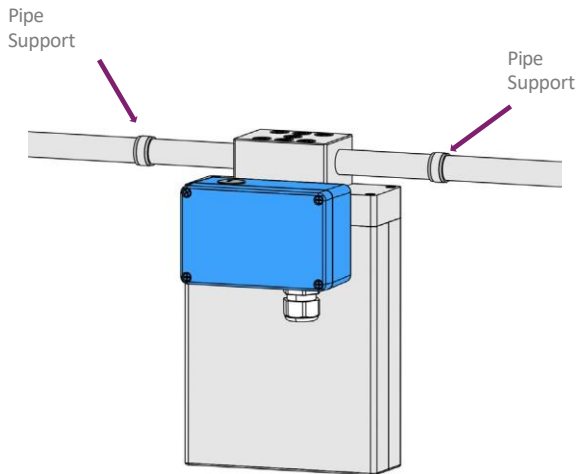

### Sensor Mounting Holes (backside of the sensor)

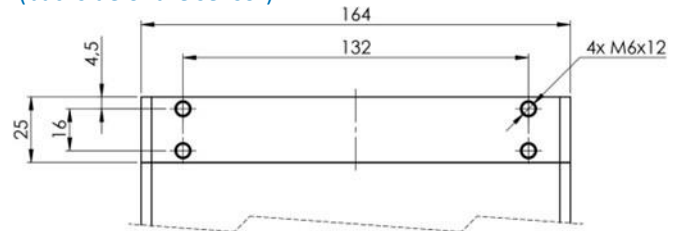

### Thread dimensions ground plate PF0/PFT

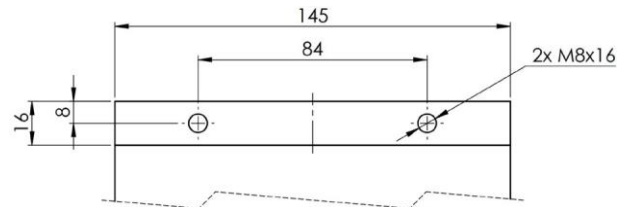

### Wall Mounting Bracket Accessory

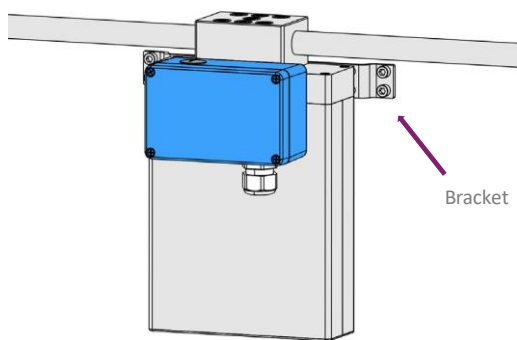

### Floor Mounting "Foot" Bracket Accessory

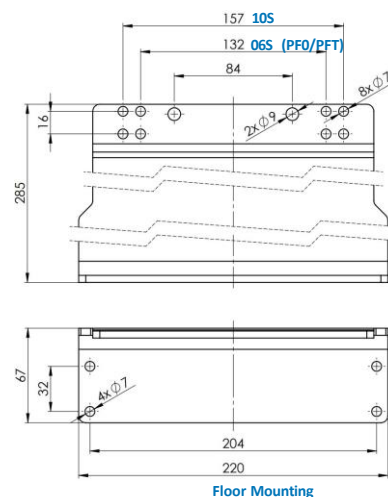
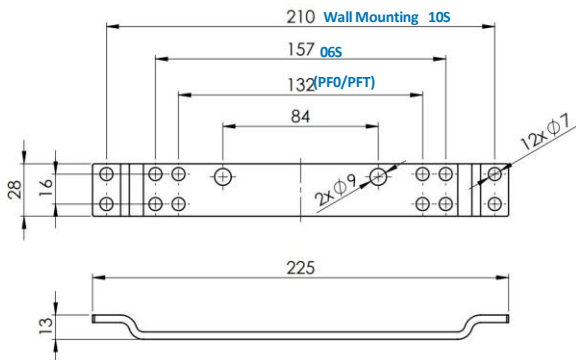
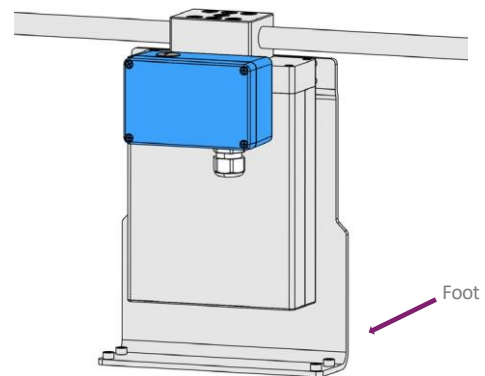

## Electrical connection to transmitter compatibility

Electrical connection option selections are compatible with the transmitter range according to the following table. Note that economical blind front versions of some transmitters are available where displays and keypads are not required. The wide range of Rheonik sensors and transmitters provide tremendous options for system designers and end users alike.

Sensor Connection Options							
	Order Code	JM	SM	TM	J5	C2	PM
	RHE 21	✓	✓	✓	—	—	✓
	RHE 26	✓	✓	✓	—	—	✓
	RHE 27	✓	✓	✓	—	—	✓
	RHE 28	✓	✓	✓	—	—	✓
	RHE 42	✓	✓	✓	—	✓	✓
	RHE 45	—	—	—	✓	—	—
	RHE 46	✓	✓	✓	—	—	✓

## Hazardous Area Certifications

Order Code	Zone / Division	Approval	Labeling
A2	Zone 2	ATEX IECEX	⊕ Ex II 3G Ex ec IIC T6...T1 Gc Ex ec IIC T6...T1 Gc
A1	Zone 1	ATEX IECEX	⊕ Ex II 2G Ex ib IIC T6...T1 Gb Ex ib IIC T6...T1 Gb
A0	Zone 0	ATEX IECEX	⊕ Ex II 1G Ex ia IIC T6...T1 Ga Ex ia IIC T6...T1 Ga
C2	Zone 2	USA/Canada	Class I, Zone 2, AEx nA IIC T6...T1 Gc
C0	Div 1, Zone 0	USA/Canada	Class I, Div 1, Groups A, B, C and D T6...T1; Class I, Zone 0, AEx ia IIC T6...T1 Ga



## 레오닉에 대해

레오닉의 목표는 최고의 Coriolis 질량유량계를 설계하고 제조하는 것입니다.

R&D 및 엔지니어링 팀은 효율적이고 정밀도가 뛰어난 새롭고 향상된 유량 솔루션을 제공하기 위해 전념하고 있으며, 생산 팀은 각각의 제품들에 대한 원자재 공급부터 제조, 운송까지 책임지고 서비스 및 지원 팀은 귀사에서 사용하는 모든 레오닉 제품을 분류, 통합, 시운전 및 유지 보수가 가능하도록 지원합니다.

레오닉 제품을 사용하신다면 귀사는 우리의 소중한 비즈니스 파트너입니다. 플랜트의 특별한 구성이 필요하다면 설치에 추가 비용이 발생하는 “표준” 제품 또는 광범위한 제품으로도 적합한 구성을 할 수 없는 경우에는 당사의 전용 “AnyPipeFit 실행”으로 어떠한 유량 센서의 크기 또는 프로세스 커넥션 타입이라도 귀사가 원하는 제품으로 “맞춤제작” 할 수 있습니다.

귀사의 주 제품으로 어떤 제어 시스템을 사용하든 당사의 AnyInterface 실행”으로 설치 및 통신에 문제가 없습니다. 레오닉 RHE 트랜스미터는 다양한 아날로그 또는 디지털 신호와 함께 모든 네트워크/bus 인터페이스 (HART, ProfibusDP, ProfiNet, EtherCAT, PowerLink, EtherNet/IP, CAN 등)를 제공합니다. 레오닉 RHE 트랜스미터는 귀사의 시스템에 (어려운 문제 및 변환이 필요 없이) 연결하여 사용 가능합니다.

(주)레오닉코리아  
#07547  
서울시 강서구 양천로 583  
우림블루나인비즈니스센터  
A동 1008호

www.rheonik.kr  
info@rheonik.kr  
02-3664-5015

