



RHM 04

Coriolis Mass Flow Meter for Batching/Filling and Accurate Measurement

General Flow Control / Additive Dosing / Mixing and Batching /
Chemical Injection / Package and Container Filling





이점

- 유량 측정 범위 18 kg/min (39.68 lb/min)
- 압력 적용 범위 1,401 bar (20,319 psi)
- 온도 적용 범위 -196 to +210 °C (-320 to +410°F) - 더 넓은 범위 가능
- 질량 유량 정밀도 0.05 %
- 재현성 0.05 %
- 40 시리즈 트랜스미터와 함께 사용시 4 kHz 측정 업데이트 및 10ms 미만의 응답 속도
- 50 g/min 미만까지 정확하게 측정
- 레오닉 [AnyPipeFit Commitment](#) 방법은 어떠한 프로세스 타입 및 사이즈에도 연결 가능하므로 설치 비용 절감
- Compact design 으로 최소 설치 공간 필요
- 방폭 인증 획득
- Stainless steel 외함 가능
- 일체형 및 분리형 트랜스미터 연결 가능

RHM04 일반 사양

Nominal Flow (Q_{nom})*	12 kg/min (26.46 lb/min)
Maximum Flow (Q_{max})*	18 kg/min (39.68 lb/min)
Typical Minimum Flow (Q_{min})*	0.06 kg/min (0.13 lb/min)
Serial Tube / Single Path	Flow rates Q_{max} , Q_{nom} and Q_{min} for "serial" sensors will be 50% of the above listed parallel/dual path version.
Operating Temperature	Fluid temperature range options cover from -196 °C to +210 °C (-320 °F to +410 °F) For integral transmitter versions please refer to transmitter datasheet
Ambient Temperature	-50 °C to +80 °C (-60 °F to +180 °F). High temperature version for oven installation up to +210 °C (+410 °F) available
Pressure Ratings	Up to 1401 bar / 20319.79 psi – dependent upon material
Electrical Connection Sensor w/o Integral Transmitter	M20 x 1.5 standard cable entry for JM, SM terminal box versions Optional entries available : ½" NPT or M25 x 1.5 (only for SM) or ¾" NPT (only for SM) M16 x 1.5 standard cable entry for PM terminal box version Max. cable length to remote RHE transmitter 100 m/330 ft.
Sensor Enclosure Materials	Stainless steel 304 (standard), SS 316 (optional) Coated aluminum terminal box, SS 316 terminal box (optional)
Enclosure Type	Protection class IP 66, NEMA 4 (standard), IP 66/67, NEMA 4X (optional)
Wetted Materials	Flow tubes SS 316L, Sandvik HP160 or SuperDuplex Manifolds SS 316L, seals FKM, FFKM, FVMQ Standard flanges SS 316Ti, other connections SS 316L Additional/customer specific materials available upon request
Process Connections	Nearly any – the Rheonik AnyPipeFit Commitment . Consult factory for types/sizes not listed in this data sheet on the Mechanical Construction pages
Pressure Rating Compliance	PED 2014/68/EU Article 4, Section 3 (SEP)
Certifications and Approvals	ATEX / IECEx Approvals Zone 0, 1, 2 (see page 19) North American Approvals Cl. I, Div. 1, 2, Gr. A, B, C, D, Zone 0, 1, 2 OIML, MID custody transfer approval American Bureau of Shipping (ABS) Product Type Approval for use on marine vessels
Testing and Inspection	All sensors are hydro tested, calibrated and supplied with a traceable calibration certificate. Customized calibration and testing services are available
Project Documentation and QA, Services	Rheonik offers a full set of services for large and complex engineering projects. Typical services offered are, but not limited to: <ul style="list-style-type: none"> • Certificates of origin and conformity, mill certificates • Data books including WPAR, WQS, NDT, test & quality plans, functional testing, calibration procedures, customized packing, factory acceptance etc. • Painting to project specification • Start up and commissioning services on/offshore
Options	Customization services for machine integration. Consult factory

* At Q_{nom} pressure drop across a parallel tube sensor will be approximately 1.6 bar (23.2 psi) for H2O. Sensors can be operated at higher flow rates up to Q_{max} but pressure drop will be higher. Typical Minimum Flow Q_{min} is the recommended lowest flow rate for an accurate measurement. Sensors will measure flow rates lower than Q_{min} but uncertainty will increase beyond 1% of rate.

The flow rate specifications above relate to standard pressure, parallel tube, manifold sensor versions. Models with higher pressure ratings have increased wall thickness and will have higher pressure drops.

Calibration Options

Standard and Premium Calibration

A	0.20 % Uncertainty <i>Requires RHE 20 Series transmitter or higher</i>
B	0.15 % Uncertainty <i>Requires RHE 20 Series transmitter or higher</i>

Premium Plus and Ultimate Calibration

G	0.10 % Uncertainty <i>Requires RHE 20 Series transmitter or higher</i>
U	0.05 % Uncertainty <i>Requires RHE 40 Series transmitter</i>

Low Flow and Customized Calibration

1	0.10 % Low Flow Focused Calibration* <i>Requires RHE 40 Series transmitter</i>
X	Customized Calibration** <i>Consult factory</i>

* Low flow calibration focuses on the range from $Q_{nom}/2$ downwards to lower flow rates than on other calibrations. Often used for low pressure gas or very viscous liquids
 ** Customized calibration uses specific calibration points according to customer requirements

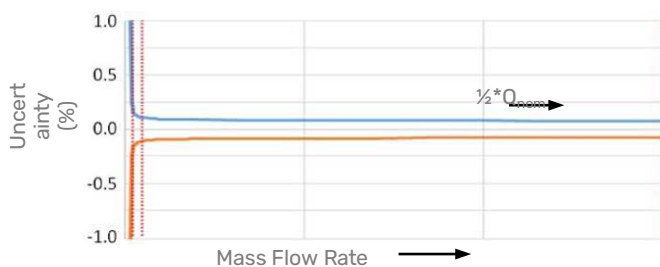

Uncertainties and flow measurement turn-down

The turn down capability from Q_{nom} of the flow sensor is driven mainly by its zero point stability. At the very low end of the measuring range the uncertainty (u) is dominated by zero point stability. The zero point stability of a standard sensor is: 0.0006 kg/min (0.00132 lbs/min). Zero point stability of a Gold Line sensor is 0.0004 kg/min (0.000882 lbs/min).

For flow $Q \geq ZP \text{ stability} / (\text{Base Calibration uncertainty}/100) \rightarrow u = \text{calibration uncertainty}$
 For flow $Q < ZP \text{ stability} / (\text{Base Calibration uncertainty}/100) \rightarrow u = (\text{zero stability}/Q) * 100$

Uncertainties from environmental and process conditions

- If sensors are not zeroed at operating conditions, minor additional uncertainties can arise from elevated temperatures and pressures: $\pm 0.001\%$ of maximum flow per $^{\circ}\text{C}$ and $\pm 0.00011\%$ of maximum flow per bar.
- Process temperature effect on density: additional uncertainty of $\pm 0.000061 \text{ g/cm}^3$ per $^{\circ}\text{C}$ difference from calibration temperature with standard density calibration and of $\pm 0.000011 \text{ g/cm}^3$ per $^{\circ}\text{C}$ difference from calibration temperature with enhanced density calibration. This effect can be mitigated by a simple field density adjustment at operating conditions.
- Process pressure effect on mass flow: The effect of pressure on flow measurement is 0.001% of rate per bar. Compensation is possible by pressure sensor input (analog input or digital write) or manual value entry into the transmitter.
- Process pressure effect on density: The effect of pressure on density measurement is 0.00002 g/cm^3 per bar. Compensation is possible by pressure sensor input (analog input or digital write) or manual value entry into the transmitter.

Premium Plus, Ultimate, Low Flow and Enhanced Density Calibration come with Gold Line sensors and are not available in all materials, pressure and temperature ranges.

Reference conditions: 18-24 $^{\circ}\text{C}$ Water @ 1-3 bar; Gas (Natural gas) 35-100 bar.

Density Calibration / Performance (Liquid)

N	No Live Density Calibration
S	Standard $\pm 0.001 \text{ kg/liter}$ Uncertainty
D	Enhanced $\pm 0.0005 \text{ kg/liter}$ Uncertainty

Flow Measurement Repeatability

Standard Sensors $\pm 0.1\%$ of rate
 Gold Line Sensors $\pm 0.05\%$ of rate

Temperature Measurement

Better than $\pm 1^{\circ}\text{C}$

Pressure Drop

Every Coriolis flow sensor generates pressure drop across its inlet and outlet when in use. The amount of pressure drop generated is mainly a function of the flow velocity within its tubes and the flowing viscosity of the stream.

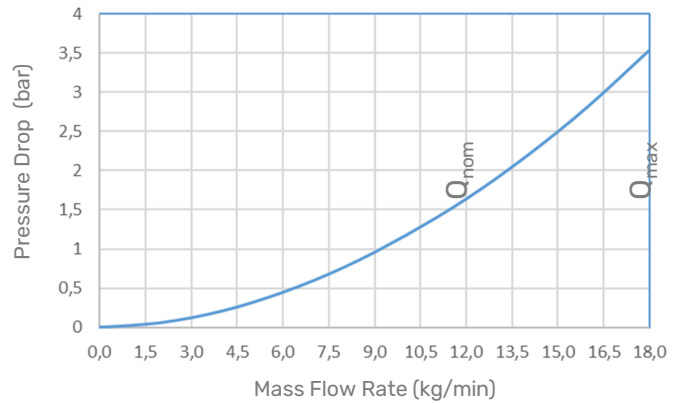

0 – 18 kg/min water, sensor with P1 pressure rating. Higher viscosities create higher pressure drop

Measurement Tube Materials and Pressure Ratings

The maximum pressure (p_{max}) of a sensor is determined by its lowest rated part. The lowest rated part can be either the measurement tube (p_{max} see table to the right), the connection block/manifold (p_{max} indicated in the mechanical construction section) or the process connection (for p_{max} see published standards or manufacturer information).

Material	Pressure Code	50°C / 122°F	120°C / 248°F	210°C / 410°F
SS 316L (standard)	P1	177 2567	157 2277	132 1915
SuperDuplex*	P2	712 10327	662 9602	594 8615
SuperDuplex*	P3	1087 15766	1048 15200	709 10283
SuperDuplex*	P4	1401 20320	1304 18913	1170 16969
Sandvik HP160	P2	600 8702	540 7832	490 7106
Sandvik HP160	P3	1087 15766	1048 15200	709 10283

SuperDuplex stainless steel is -40 °C Units: bar / psi

Other Materials

Other wetted materials may be possible for chemical compatibility, lower pressure drop, abrasion allowance, other application specific requirements. Rheonik can provide nearly any material for the wetted parts.
Contact factory with specification for assessment and availability.

Mechanical Construction

Sensors are manufactured with two internal measurement tubes arranged side by side. In parallel or dual path sensors (order code Pxx), these tubes are connected in parallel and the flowing fluid is split equally between them. In serial or single path sensors (order code Sxx), the internal tubes are connected end to end, creating a single path through which all fluid flows. Manifold designs have a removable inlet/outlet manifold block and utilize selectable seals between the manifold and sensor body. In sealless designs, the measurement tubes are continuous between the process connections and do not have seals. Manifold designs offer shorter delivery lead times and may have a lower pressure drop than sealless designs for the same flow rate.

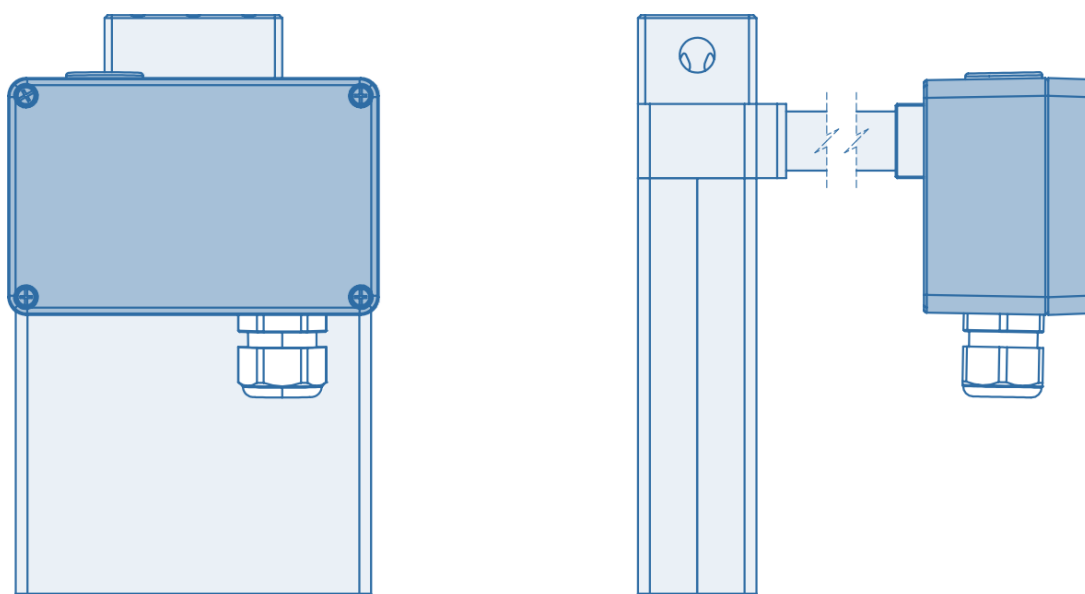

Note

All dimensions are for standard products. For customization of face to face length and/or process connection types other than the ones listed on this page, please consult factory. Note that larger diameter flange process connections are always possible.

Manifold design with thread connections

PM0/PH0: parallel tube / dual path

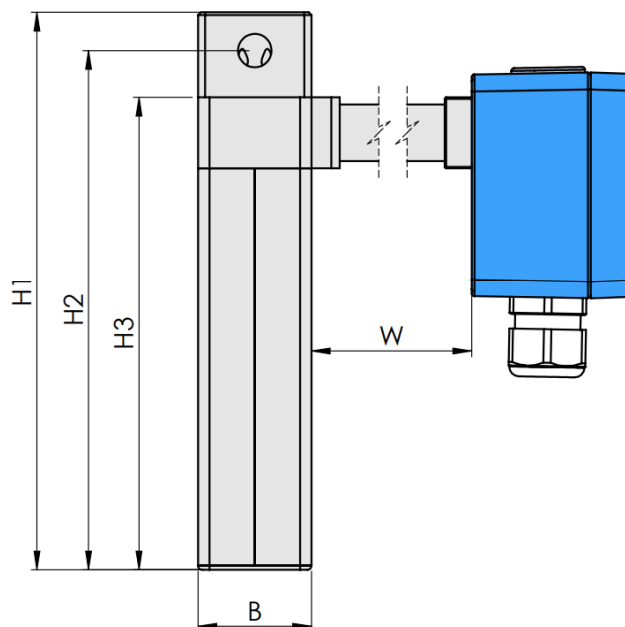
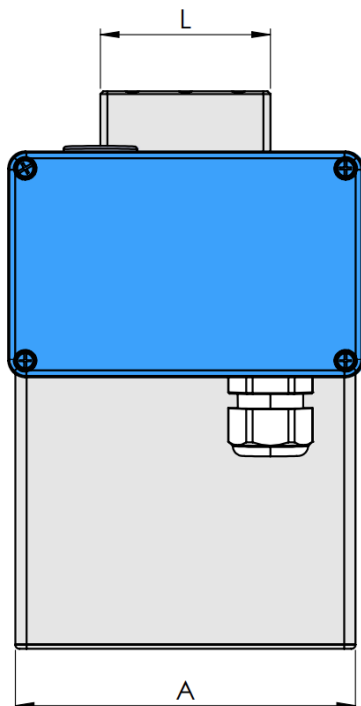

Process Connection PM0 / PH0	Dim. L mm / in	Order Code
Female Thread G 1/4" (only PM0)	60 / 2.36	G1
Female Thread 1/4" NPT (only PM0)	60 / 2.36	N1
Autoclave 3/8" MP - 1/8" - 18 UNF Female Thread (only PH0)	70 / 2.76	P1

PM0 / PH0 Dimensions	mm	in
A	120	4.72
B	40	1.57
H1 (PM0, PH0)	222	8.74
H2	208	8.19
H3	192	7.56
W	see page 14	

Manifold Pressure Ratings @ 120 °C / 248 °F

PM0 – 700 bar / 10150 psi
 PH0 – 1220 bar / 17695 psi
 (20000 psi @ 50 °C / 122 °F)

Weights and Shipping Dimensions

- Weight for sensor with threads: ~3.5 kg/7.7 lb
- Shipping carton size ~60 x 41 x 32 cm (24 x 16 x 13 in)
- Gross weight with RHE 28, packaging ~9.5 kg/20.9 lb

Material of Manifold Seals (Wetted Part)

Depending upon sensor temperature range, sensors are supplied with the following seal types as standard. For alternative seal options (e.g. FFKM seals for N1) please see Options. Other seals on request.

Temperature Range	PM0	SM0	PH0	SH0
N1	FKM	FKM	FKM	FKM
NA	FVMQ	FVMQ	FVMQ	FVMQ
E2*	FFKM	FFKM	n/a	n/a

*FFKM seals minimum temperature is -20 °C/-4 °F; p_{max} = 700 bar

Manifold design with thread connections

SM0/SH0: serial tube / single path

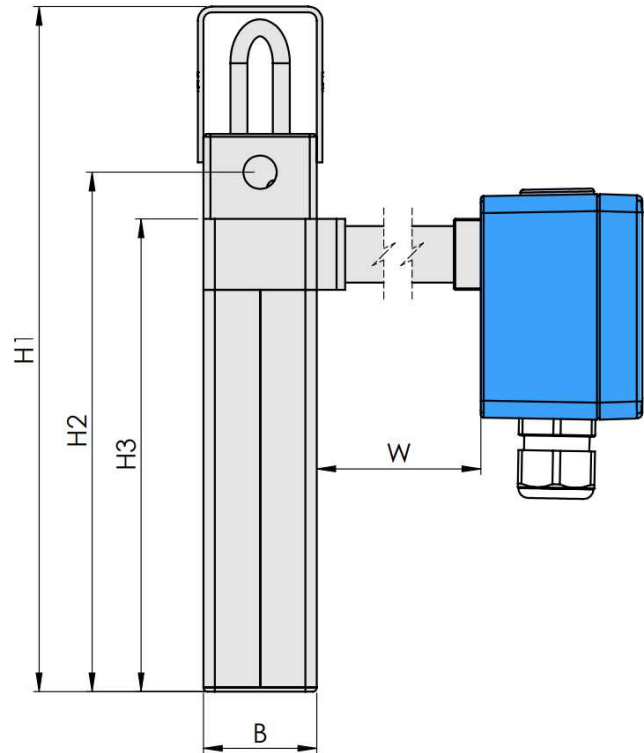
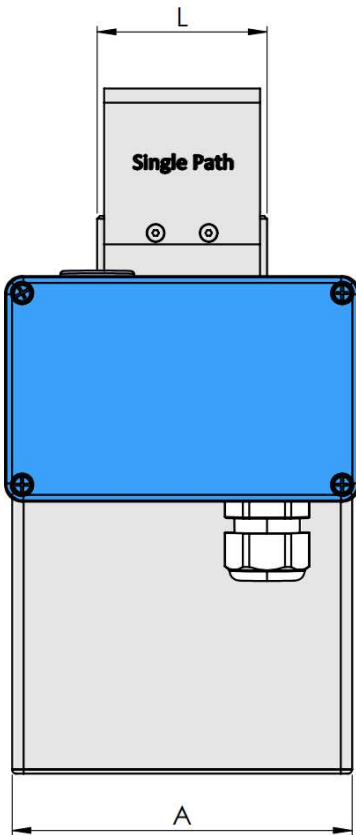

Process Connection SM0 / SH0	Dim. L mm / in	Order Code
Female Thread G ¼" (only SM0)	60 / 2.36	G1
Female Thread ¼" NPT (only SM0)	60 / 2.36	N1
Autoclave ⅜" MP - ⅝" - 18 UNF Female Thread (only SH0)	70 / 2.76	P1

Manifold Pressure Ratings @ 120 °C / 248 °F

SM0 – 700 bar / 10150 psi
 SH0 – 1220 bar / 17695 psi
 (20000 psi @ 50 °C / 122 °F)

SM0 / SH0 Dimensions	mm	in
A	120	4.72
B	40	1.57
H1 (SM0, SH0)	267	10.51
H2	208	8.19
H3	192	7.56
W	see page 14	

Weights and Shipping Dimensions

- Weight for sensor with threads: ~3.5 kg/7.7 lb
- Shipping carton size ~60 x 41 x 32 cm (24 x 16 x 13 in)
- Gross weight with RHE 28, packaging ~9.5 kg/20.9 lb

Material of Manifold Seals (Wetted Part)

Depending upon sensor temperature range, sensors are supplied with the following seal types as standard. For alternative seal options (e.g. FFKM seals for N1) please see Options. Other seals on request.

Temperature Range	PM0	SM0	PH0	SH0
N1	FKM	FKM	FKM	FKM
NA	FVMQ	FVMQ	FVMQ	FVMQ
E2*	FFKM	FFKM	n/a	n/a

*FFKM seals minimum temperature is -20 °C/-4 °F; pmax = 700 bar

Manifold design with flange connections

PMO: parallel tube / dual path

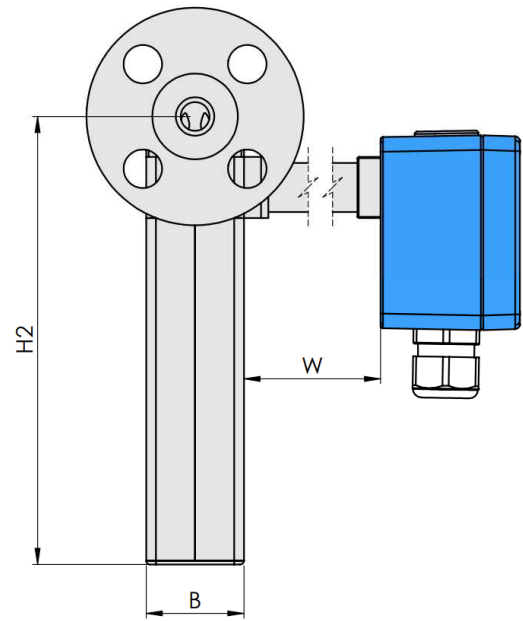
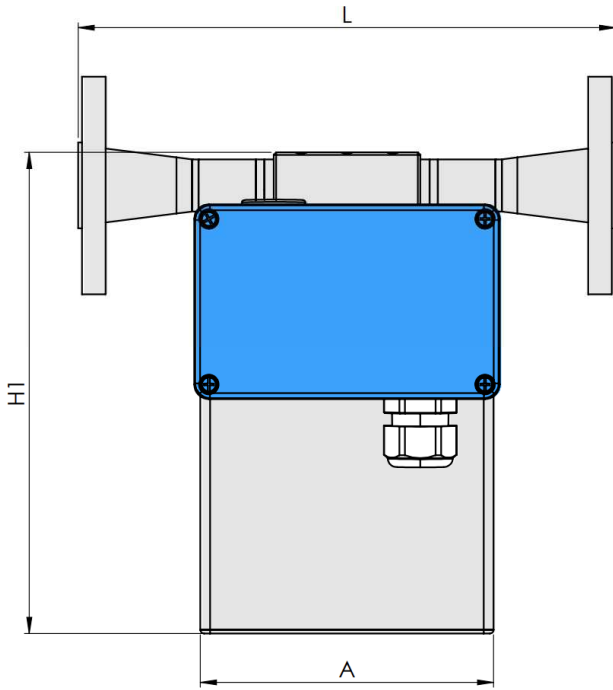

Process Connection PMO	Dim. L mm / in	Order Code
Flange ANSI ½" 150#RF	220 / 8.66	A1
Flange ANSI ½" 300#RF	220 / 8.66	A2
Flange ANSI ½" 600#RF	220 / 8.66	A3
Flange ANSI ½" 1500#RF	300 / 11.81	A4
Flange ANSI ½" 1500#RTJ	300 / 11.81	R1
Flange DIN DN15/PN40	220 / 8.66	D1
Flange DIN DN15/PN100	220 / 8.66	D2
Flange DIN DN15/PN160	220 / 8.66	D3
Flange JIS B 2220 RF 10k 15A	220 / 8.66	J1
Flange JIS B 2220 RF 20k 15A	220 / 8.66	J2

PMO Dimensions	mm	in
A	120	4.72
B	40	1.57
H1 (PMO)	222	8.74
H2	208	8.19
H3	192	7.87
W	see page 14	

Weights and Shipping Dimensions

- Weight for sensor with ½" 150# flanges: ~4.5 kg/9.9 lb
- Shipping carton size ~60 x 41 x 32 cm (24 x 16 x 13 in)
- Gross weight with RHE 28, packaging ~10.5 kg/23.1 lb

Material of Manifold Seals (Wetted Part)

Depending upon sensor temperature range, sensors are supplied with the following seal types as standard. For alternative seal options (e.g. FFKM seals for N1) please see Options. Other seals on request.

Temperature Range	PMO
N1	FKM
NA	FVMQ
E2	FFKM*

*FFKM seals minimum temperature is -20 °C/-4 °F

Manifold design with flange connections

SMO: serial tube / single path

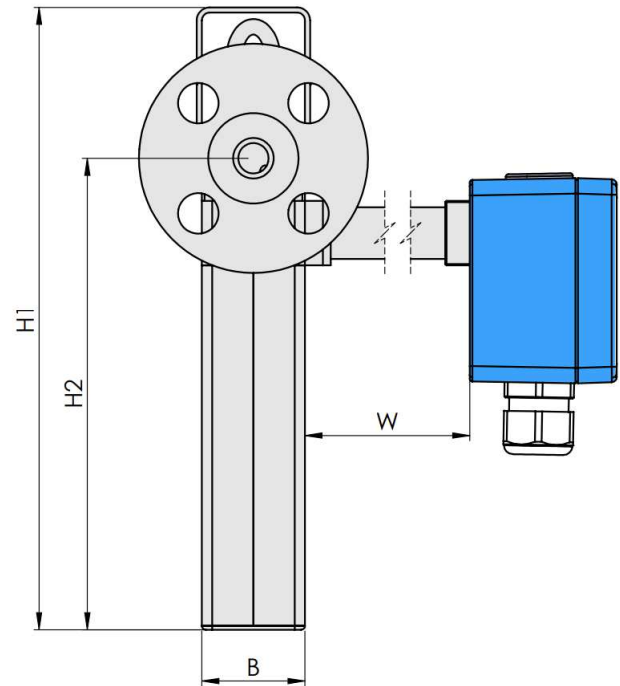
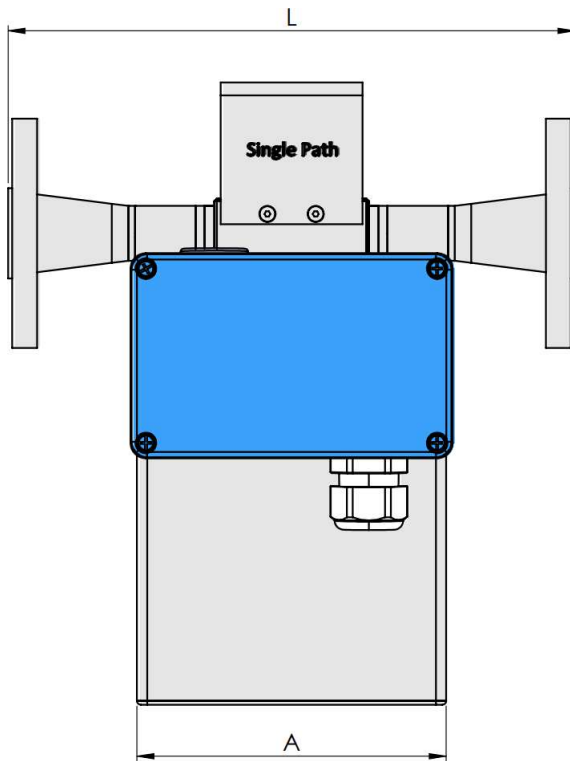

Process Connection SMO	Dim. L mm / in	Order Code
Flange ANSI ½" 150#RF	220 / 8.66	A1
Flange ANSI ½" 300#RF	220 / 8.66	A2
Flange ANSI ½" 600#RF	220 / 8.66	A3
Flange ANSI ½" 1500#RF	300 / 11.81	A4
Flange ANSI ½" 1500#RTJ	300 / 11.81	R1
Flange DIN DN15/PN40	220 / 8.66	D1
Flange DIN DN15/PN100	220 / 8.66	D2
Flange DIN DN15/PN160	220 / 8.66	D3
Flange JIS B 2220 RF 10k 15A	220 / 8.66	J1
Flange JIS B 2220 RF 20k 15A	220 / 8.66	J2

SMO Dimensions	mm	in
A	120	4.72
B	40	1.57
H1 (SMO)	267	10.51
H2	208	8.19
H3	192	7.56
W	see page 14	

Weights and Shipping Dimensions

- Weight for sensor with ½" 150# flanges: ~4.5 kg/9.9 lb
- Shipping carton size ~60 x 41 x 32 cm (24 x 16 x 13 in)
- Gross weight with RHE 28, packaging ~10.5 kg/23.1 lb

Material of Manifold Seals (Wetted Part)

Depending upon sensor temperature range, sensors are supplied with the following seal types as standard. For alternative seal options (e.g. FFKM seals for N1) please see Options. Other seals on request.

Temperature Range	SMO
N1	FKM
NA	FVMQ
E2	FFKM*

*FFKM seals minimum temperature is -20 °C/-4 °F

Sealless design with flange connections

PFO: parallel / dual path

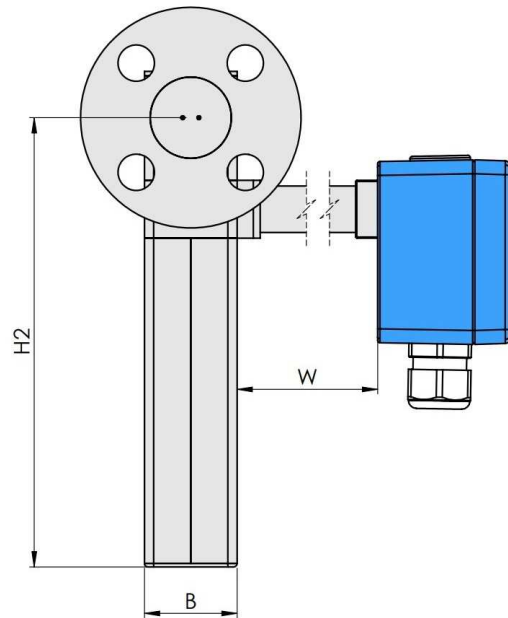
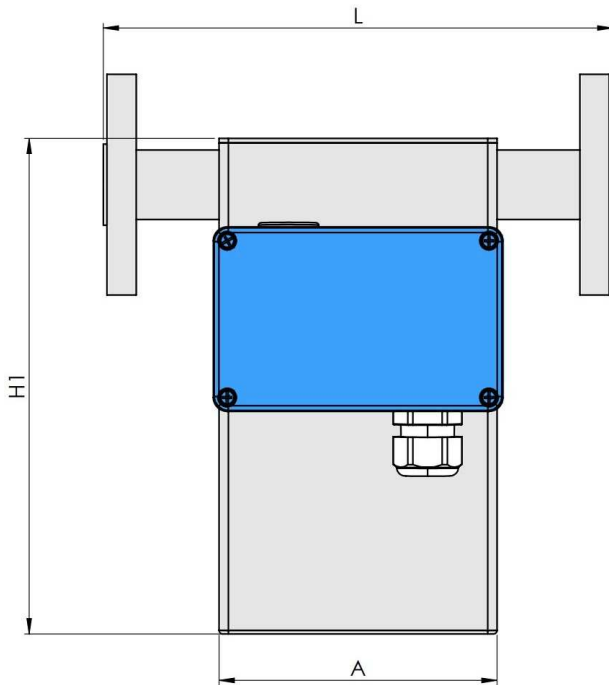

PFO Process Connection	Dim. L mm / in	Order Code
Flange ANSI ½" 150#RF	236 / 9.29	A1
Flange ANSI ½" 300#RF	236 / 9.29	A2
Flange ANSI ½" 600#RF	236 / 9.29	A3
Flange ANSI ½" 1500#RF	316 / 12.44	A4
Flange ANSI ½" 2500#RF	316 / 12.44	A5
Flange ANSI ½" 1500#RTJ	316 / 12.44	R1
Flange ANSI ½" 2500#RTJ	316 / 12.44	R2
Flange DIN DN15/PN40 Form B1	236 / 9.29	D1
Flange DIN DN15/PN100 Form B2	236 / 9.29	D2
Flange DIN DN15/PN160 Form B2	236 / 9.29	D3
Flange JIS B 2220 RF 10k 15A	236 / 9.29	J1
Flange JIS B 2220 RF 20k 15A	236 / 9.29	J2
Grayloc® Hub 1" GR4	316 / 12.44	H1

PFO Dimensions	mm	in
A	136	5.35
B	40	1.57
H1	247	9.72
H2	227	8.94
H3	200	7.87
W	see page 14	

For other hub connections (e.g. Destec, Galperti, Techlok) please consult factory

Weights and Shipping Dimensions

- Weight for sensor with ½" 150# flanges: 4 kg/8.8 lb
- Shipping carton size ~60 x 41 x 32 cm (24 x 16 x 13 in)
- Gross weight with RHE 28, packaging ~10 kg/22 lb

Sealless design with threaded connections

PFT: parallel / dual path

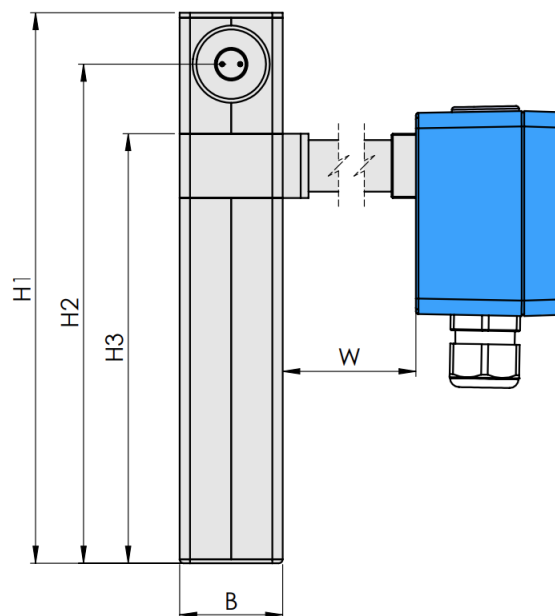
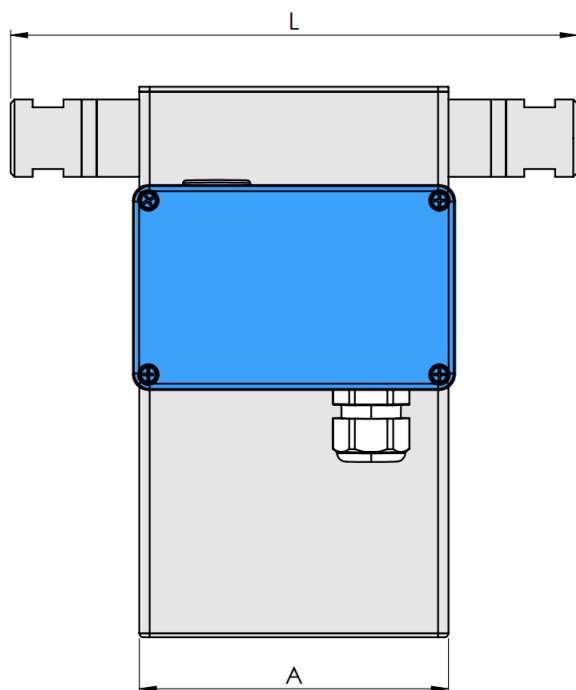

Process Connection PFT	Dim. L mm / in	Order Code
Female Thread G 1/4"	236 / 9.29	G1
Female Thread 1/4" NPT	236 / 9.29	N1
Autoclave 3/8" MP - 9/16" - 18 UNF Female Thread	236 / 9.29	P1
Swagelok® 1/4" Tube Inlet male (SS-400-1-4W)	236 / 9.29	W1
Swagelok® 1/4" O-Ring Connection male (SS-4-VCO-1)	Consult Factory	V1
Swagelok® 1/4" O-Ring Connection female (SS-4-VCO-3 and -4)	Consult Factory	V2
Swagelok® 1/4" with Metal Gasket female (SS-4-VCR-1 and -3)	Consult Factory	V3

PFT Dimensions	mm	in
A	136	5.35
B	40	1.57
H1	247	9.72
H2	227	8.94
H3	200	7.87
W	see page 14	

Weights and Shipping Dimensions

- Weight for sensor with threads: ~3 kg/6.6 lb
- Shipping carton size ~60 x 41 x 32 cm (24 x 16 x 13 in)
- Gross weight with RHE 28, packaging ~9 kg/19.8 lb

Sealless design with threaded connections

PMT: parallel / dual path

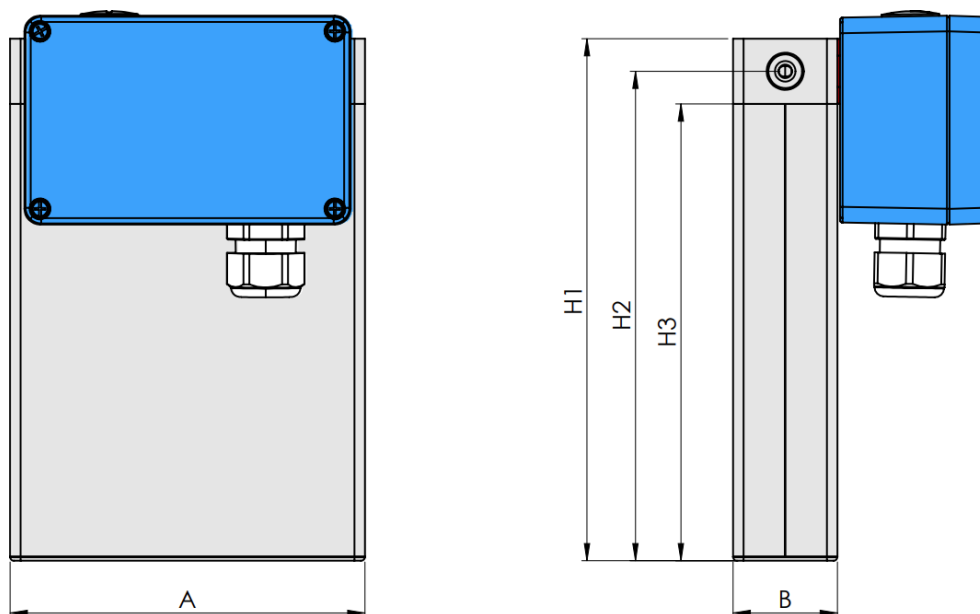

Process Connection PMT	Dim. A mm / in	Order Code
Autoclave 3/8" MP - 9/16" - 18 UNF female thread	136 / 4.72	P1

PMT Common Dimensions	mm	in
A	136	5.35
B	40	1.57
H1 (PMT)	200	7.87
H2 (PMT)	188	7.40
H3 (PMT)	175	6.89

Weights and Shipping Dimensions

- Weight for sensor with threads: ~3 kg/6.6 lb
- Shipping carton size ~60 x 41 x 32 cm (24 x 16 x 13 in)
- Gross weight with RHE 28, packaging ~9 kg/19.8 lb

Electrical Connection Options for remote RHE20, RHE40 Transmitters

JM Standard Terminal Box
Coated Aluminum

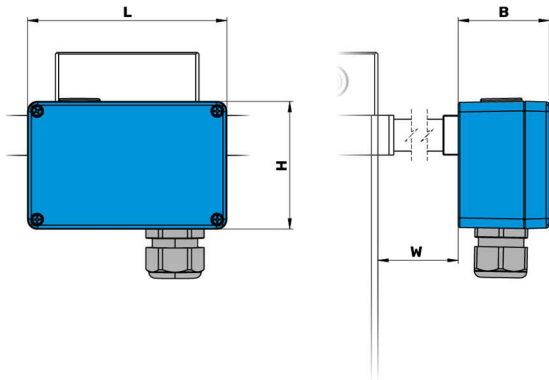

PM Extra Compact Terminal
Box Coated Aluminum

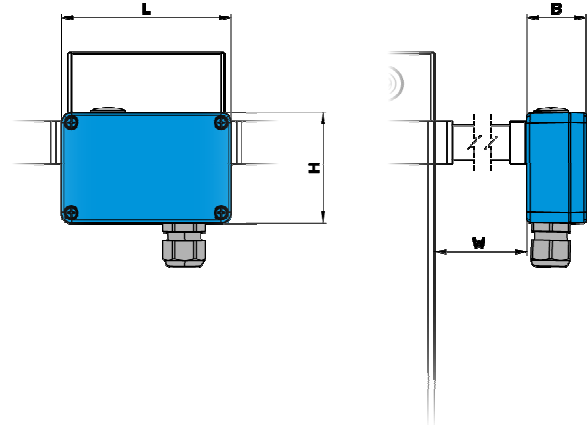

SM Terminal Box and Entire Enclosure
Stainless Steel 316

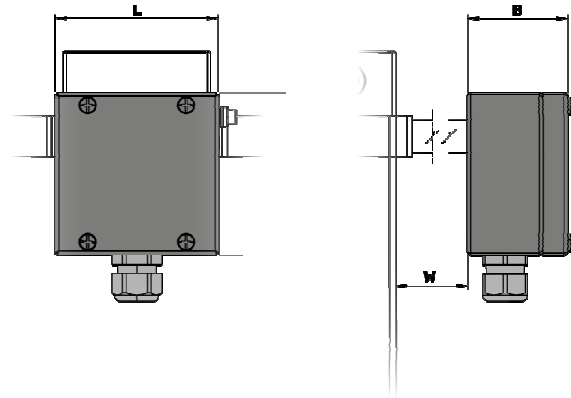

TM Integral PTFE Cable Instead of Terminal Box
Standard Length 2 m. Can be extended up to
max 10 m

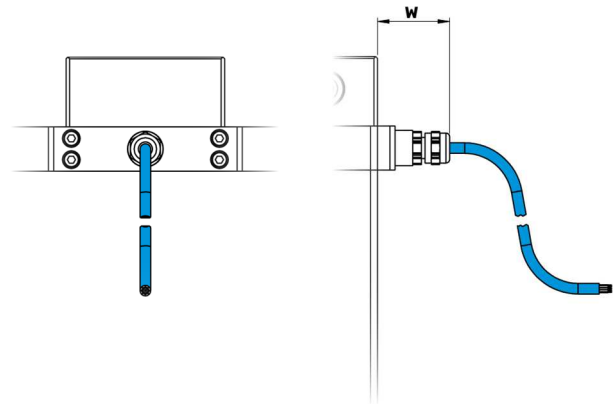

Electrical Connection Dimensions	mm	in
J5, JM Standard Box (L x H x B)	125 x 80 x 57	4.92 x 3.15 x 2.24
PM Compact Box (L x H x B)	98 x 64 x 34	3.86 x 2.52 x 1.34
SM SS316 Box (L x H x B)	100 x 100 x 61	3.94 x 3.94 x 2.40
TM Integral PTFE Cable (W)	41	1.61
Temperature Range N1, NA (W)	2	0.08
Temperature Range E2, E3, H4 (W)	100	3.94

JM, SM Terminal boxes are supplied with an M20 x 1.5 cable entry, optional entries are available
 PM Compact Terminal boxes are supplied with an M16 x 1.5 cable entry
 For integral transmitter version J5 please refer to RHE45 datasheet

Mounting Schemes

Standard/Usual Installation Without Mounting Brackets

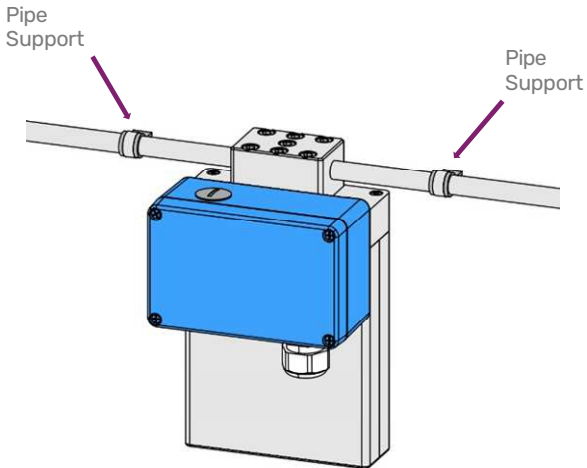

Thread dimensions base plate PMO (backside of the sensor)

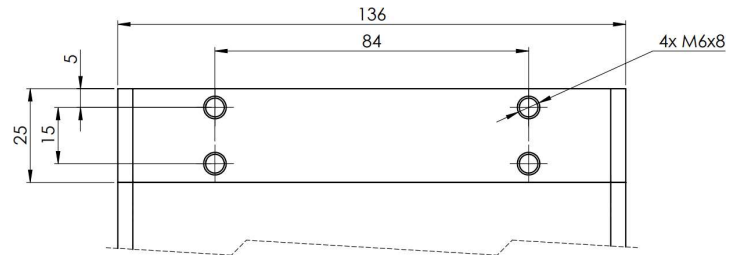

Mounting Aids for special Installation requirements

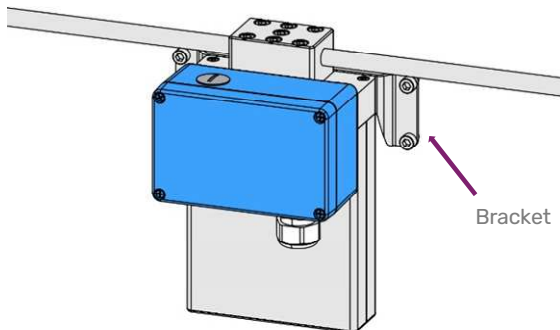

Type M - Wall Mount

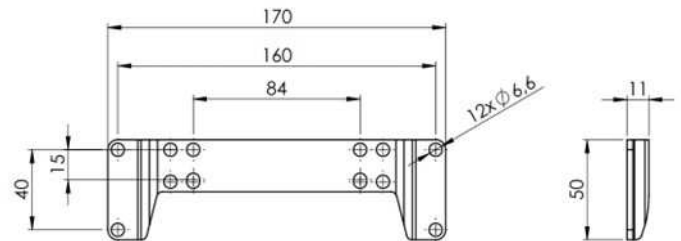

Type MF - Floor Mount

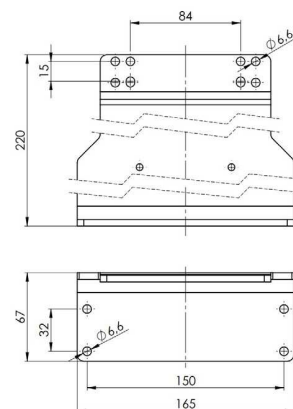

Transmitter Range

Any Rheonik Mass Flow Transmitter model can be combined with any Rheonik Mass Flow Sensor to provide an overall mass flow measurement system to suit any requirement. Rheonik Coriolis Transmitters are available in versions specifically designed for process, industrial and OEM applications. Economical blind front versions of some transmitters are available where displays and keypads are not required. The wide range of sensors and transmitters provide tremendous options for system designers and end users alike.

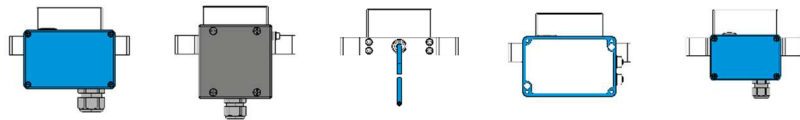

Product Code	JM	SM	TM	J5	PM
 RHE 21	✓	✓	✓	-	✓
 RHE 26	✓	✓	✓	-	✓
 RHE 27	✓	✓	✓	-	✓
 RHE 28	✓	✓	✓	-	✓
 RHE 42	✓	✓	✓	-	✓
 RHE 45	-	-	-	✓	-

Hazardous Area Certifications

Code	Zone / Division	Approval		Labeling
A0	Zone 0	ATEX		II 1G Ex ia IIC T6...T1 Ga
A1	Zone 1	ATEX		II 2G Ex ib IIC T6...T1 Gb
A2	Zone 2	ATEX		II 3G Ex ec IIC T6...T1 Gc
A0	Zone 0	IECEX		Ex ia IIC T6...T1 Ga
A1	Zone 1	IECEX		Ex ib IIC T6...T1 Gb
A2	Zone 2	IECEX		Ex ec IIC T6...T1 Gc
C0	Div 1, Zone 0	Zone USA/Canada		Class I, Div 1, Groups A, B, C and D T6...T1; Class I, Zone 0, AEx ia IIC T6...T1 Ga
C2	Zone 2	Zone USA/Canada		Class I, Zone 2, AEx nA IIC T6...T1 Gc

레오닉에 대해

레오닉의 목표는 최고의 Coriolis 질량유량계를 설계하고 제조하는 것입니다.

R&D 및 엔지니어링 팀은 효율적이고 정밀도가 뛰어난 새롭고 향상된 유량 솔루션을 제공하기 위해 전념하고 있으며, 생산 팀은 각각의 제품들에 대한 원자재 공급부터 제조, 운송까지 책임지고 서비스 및 지원 팀은 귀사에서 사용하는 모든 레오닉 제품을 분류, 통합, 시운전 및 유지 보수가 가능하도록 지원합니다.

레오닉 제품을 사용하신다면 귀사는 우리의 소중한 비즈니스 파트너입니다. 플랜트의 특별한 구성이 필요하다면 설치에 추가 비용이 발생하는 “표준” 제품 또는 광범위한 제품으로도 적합한 구성을 할 수 없는 경우에는 당사의 전용 “AnyPipeFit 실행” 으로 어떠한 유량 센서의 크기 또는 프로세스 커넥션 타입이라도 귀사가 원하는 제품으로 “맞춤제작” 할 수 있습니다.

귀사의 주 제품으로 어떤 제어 시스템을 사용하든 당사의 “AnyInterface 실행” 으로 설치 및 통신에 문제가 없습니다. 레오닉 RHE 트랜스미터는 다양한 아날로그 또는 디지털 신호와 함께 모든 네트워크/bus 인터페이스 (HART, ProfibusDP, ProfiNet, EtherCAT, PowerLink, EtherNet/IP, CAN 등)를 제공합니다. 레오닉 RHE 트랜스미터는 귀사의 시스템에 (어려운 문제 및 변환이 필요 없이) 연결하여 사용 가능합니다.



(주)레오닉코리아

#07547

서울시 강서구 양천로 583

우림블루나인 비즈니스센터

A동 1008호

www.rheonik.kr
info@rheonik.kr
02-3664-5015

